

# CHERRYMAN



# 2024/2025

SPECIFICATION GUIDE & PRICE LIST  
EFFECTIVE JULY 1<sup>ST</sup>, 2024

## ABOUT US

For the past 2 decades, Cherry Man has set the standard for value in the commercial furniture industry.

Explore our Amber Collection, featuring desks, modular conference tables, and storage components that deliver unmatched quality, value, versatility, and appeal.

Our Seating Collections offer quality, design and function to complete your office designs.



SHOWN  
415B | Eon Task Chair Black

## TABLE OF CONTENTS

### AMBER COLLECTION

FINISHES	/ 04
RENDERED COMPONENTS	/ 06
DESK TYPICALS	/ 10
L-DESK TYPICALS	/ 22
U-DESK TYPICALS	/ 28
RECEPTION DESK TYPICALS	/ 34
TABLES	/ 38
COMPONENTS	/ 44
SPECIFICATIONS	/ 52

### SEATING COLLECTIONS

JEPPE	/ 57
EON	/ 58
OROBLANCO	/ 60

WARRANTY	/ 62
DESIGN RESOURCE	/ 63
TERMS & CONDITIONS	/ 64
ENVIRONMENTAL COMMITMENT	/ 65
OUR TEAM	/ 66

# AMBER

The Benchmark for  
Laminate Casegoods

Amber relays a timeless design for defining dynamic work environments. Built to last with an extensive product offering and multiple vibrant finishes, Amber provides unparalleled value that maximizes the return on investment.

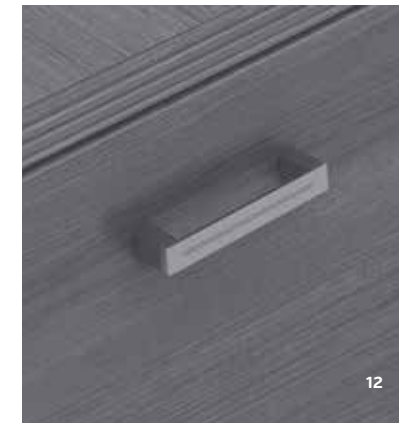

#### COLORS / MATERIALS / FINISHES

- / 01 – PULL FINISH / SATIN NICKEL ALUMINUM
- / 02 – WOOD GRAIN FINISH / PARK WALNUT LAMINATE
- / 03 – AM-421N.WLNT U-DESK / PARK WALNUT LAMINATE
- / 04 – AM-421N.MAHO U-DESK / SIENNA MAHOGANY LAMINATE
- / 05 – WOOD GRAIN FINISH / SIENNA MAHOGANY LAMINATE
- / 06 – PULL FINISH / BLACK ALUMINUM
- / 07 – PULL FINISH / SATIN NICKEL ALUMINUM
- / 08 – WOOD GRAIN FINISH / BLACK CHERRY LAMINATE
- / 09 – AM-421N.BLKC U-DESK / BLACK CHERRY LAMINATE
- / 10 – AM-421N.GREY U-DESK / VALLEY GREY LAMINATE
- / 11 – WOOD GRAIN FINISH / VALLEY GREY LAMINATE
- / 12 – PULL FINISH / SATIN NICKEL ALUMINUM



Typicals  
**AMBER**

Amber offers a cohesive suite of desks, offices, and reception areas, complemented by seating, conference tables, and a variety of storage solutions. It showcases quality construction with finishes available in Park Walnut, Sienna Mahogany, Black Cherry, and Valley Grey.

SHOWN  
AM-426N.GREY | U-Desk. Configuration Valley Grey  
403W | Oroblanco Guest Chair Grey  
402W | Oroblanco Task Chair

# DESKS

AMBER TYPICALS









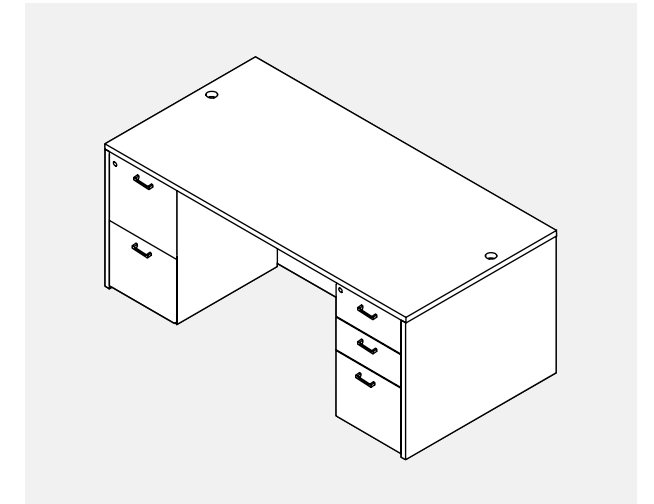









SHOWN: AM-370N.WLNT  
Desk Rectangular Double Pedestal

## DESK

Rectangular  
Double Pedestal



Product Code		D	W	H	Weight lbs.	Cubic ft.	Cartons	List Price
<b>AM-370N.MAHO</b>	 <i>desk</i>	<b>30</b>	<b>60</b>	29	112	3.89	1	<b>\$1,528</b>
<b>AM-370N.BLKC</b>	 <i>ped 2b1f</i>	22	15½	28	86	7.63	1	
<b>AM-370N.WLNT</b>	 <i>ped 2f</i>	22	15½	28	78	7.63	1	
<b>AM-370N.GREY</b>								
<b>AM-301N.MAHO</b>	 <i>desk</i>	<b>30</b>	<b>66</b>	29	126	4.27	1	<b>\$1,568</b>
<b>AM-301N.BLKC</b>	 <i>ped 2b1f</i>	22	15½	28	86	7.63	1	
<b>AM-301N.WLNT</b>	 <i>ped 2f</i>	22	15½	28	78	7.63	1	
<b>AM-301N.GREY</b>								
<b>AM-415N.MAHO</b>	 <i>desk</i>	<b>30</b>	<b>71</b>	29	130	4.41	1	<b>\$1,688</b>
<b>AM-415N.BLKC</b>	 <i>ped 2b1f</i>	22	15½	28	86	7.63	1	
<b>AM-415N.WLNT</b>	 <i>ped 2f</i>	22	15½	28	78	7.63	1	
<b>AM-415N.GREY</b>								
<b>AM-302N.MAHO</b>	 <i>desk</i>	<b>36</b>	<b>71</b>	29	150	5.34	1	<b>\$1,688</b>
<b>AM-302N.BLKC</b>	 <i>ped 2b1f</i>	22	15½	28	86	7.63	1	
<b>AM-302N.WLNT</b>	 <i>ped 2f</i>	22	15½	28	78	7.63	1	
<b>AM-302N.GREY</b>								

# DESK

Rectangular  
Double Pedestal  
Suspended

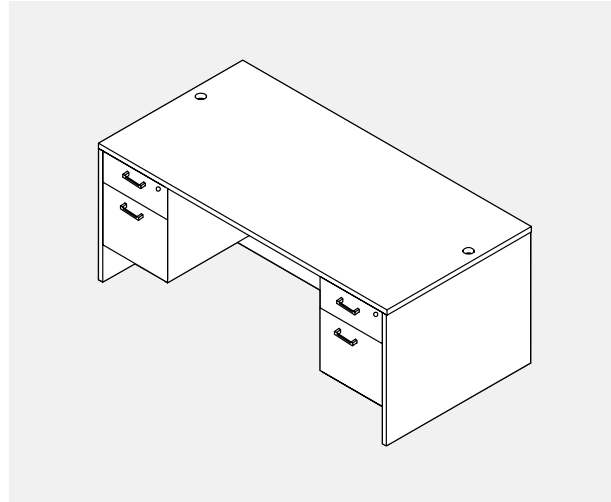

Product Code		D	W	H	Weight lbs.	Cubic ft.	Cartons	List Price
<b>AM-371N.MAHO</b>	desk	<b>30</b>	<b>60</b>	29	112	3.89	1	<b>\$1,272</b>
<b>AM-371N.BLKC</b>	ped 1b1f	22	15½	20	62	5.82	1	
<b>AM-371N.WLNT</b>	ped 1b1f	22	15½	20	62	5.82	1	
<b>AM-371N.GREY</b>								
<b>AM-303N.MAHO</b>	desk	<b>30</b>	<b>66</b>	29	126	4.27	1	<b>\$1,312</b>
<b>AM-303N.BLKC</b>	ped 1b1f	22	15½	20	62	5.82	1	
<b>AM-303N.WLNT</b>	ped 1b1f	22	15½	20	62	5.82	1	
<b>AM-303N.GREY</b>								
<b>AM-416N.MAHO</b>	desk	<b>30</b>	<b>71</b>	29	130	4.41	1	<b>\$1,432</b>
<b>AM-416N.BLKC</b>	ped 1b1f	22	15½	20	62	5.82	1	
<b>AM-416N.WLNT</b>	ped 1b1f	22	15½	20	62	5.82	1	
<b>AM-416N.GREY</b>								
<b>AM-304N.MAHO</b>	desk	<b>36</b>	<b>71</b>	29	150	5.34	1	<b>\$1,432</b>
<b>AM-304N.BLKC</b>	ped 1b1f	22	15½	20	62	5.82	1	
<b>AM-304N.WLNT</b>	ped 1b1f	22	15½	20	62	5.82	1	
<b>AM-304N.GREY</b>								

# DESK

Bowfront  
Double Pedestal  
Suspended

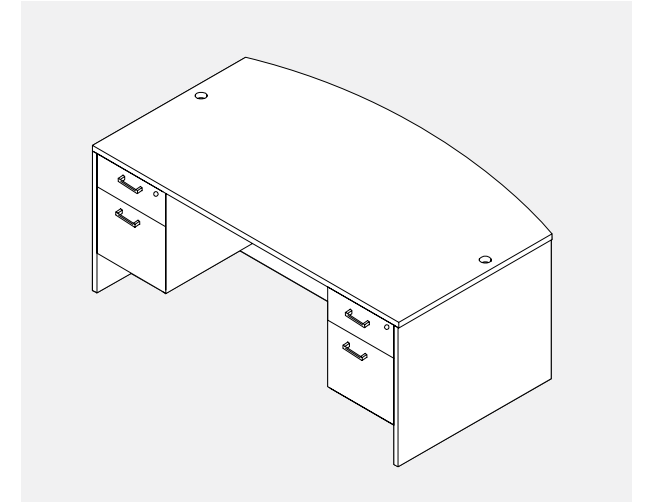

Product Code		D	W	H	Weight lbs.	Cubic ft.	Cartons	List Price
<b>AM-306N.MAHO</b>	desk	35½/41	71	29	180	6.14	1	<b>\$1,488</b>
<b>AM-306N.BLKC</b>	ped 1b1f	22	15½	20	62	5.82	1	
<b>AM-306N.WLNT</b>	ped 1b1f	22	15½	20	62	5.82	1	
<b>AM-306N.GREY</b>								

# DESK

## Bowfront Double Pedestal

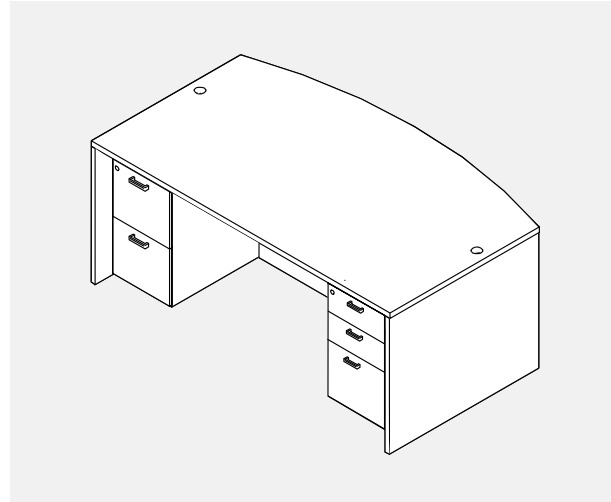

Product Code		D	W	H	Weight lbs.	Cubic ft.	Cartons	List Price
<b>AM-305N.MAHO</b>	desk	35½/41	71	29	180	6.14	1	<b>\$1,744</b>
<b>AM-305N.BLKC</b>	ped 2b1f	22	15½	28	86	7.63	1	
<b>AM-305N.WLNT</b>	ped 2f	22	15½	28	78	7.63	1	
<b>AM-305N.GREY</b>								

# DESK

## Credenza with Hutch Configuration

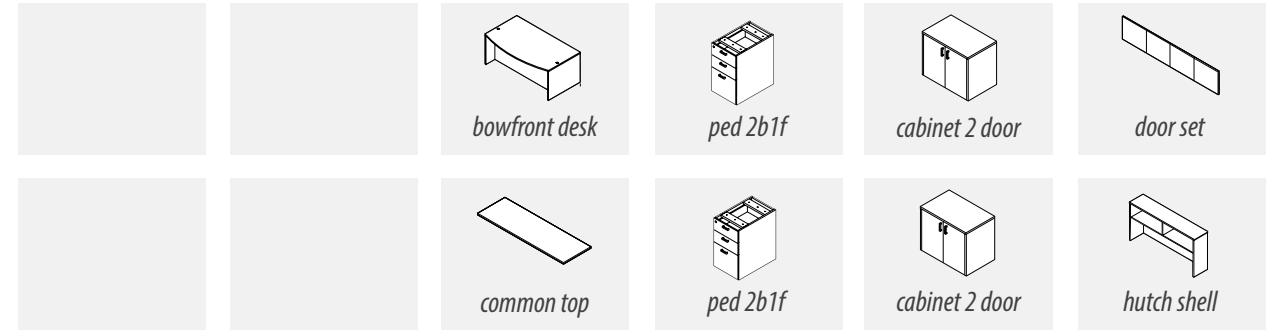
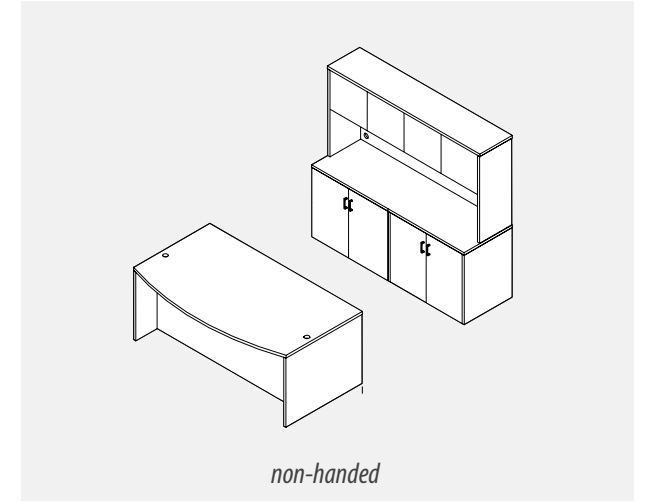

Product Code		D	W	H	Weight lbs.	Cubic ft.	Cartons	List Price
<b>AM-383N.MAHO</b>	desk	35½/41	71	29	180	6.14	1	<b>\$3,624</b>
<b>AM-383N.BLKC</b>	ped 2b1f	22	15½	28	86	7.63	1	
<b>AM-383N.WLNT</b>	ped 2b1f	22	15½	28	86	7.63	1	
<b>AM-383N.GREY</b>	cabinet 2d	23	35½	29	148	16.83	1	
	*flat edge cabinet 2d	23	35½	29	148	16.83	1	
	hutch shell	15	71	36	123	5.30	1	
	doors	¾	69¼	15	22	1.24	1	
	top	22½	71	1	46	1.00	1	
<b>AM-390N.MAHO</b>								<b>\$3,880</b>
<b>AM-390N.BLKC</b>								
<b>AM-390N.WLNT</b>								
<b>AM-390N.GREY</b>								
	with doors aluminum frame glass	¾	69¼	15	21	1.24	1	



# DESK

## Bowfront Office Configuration

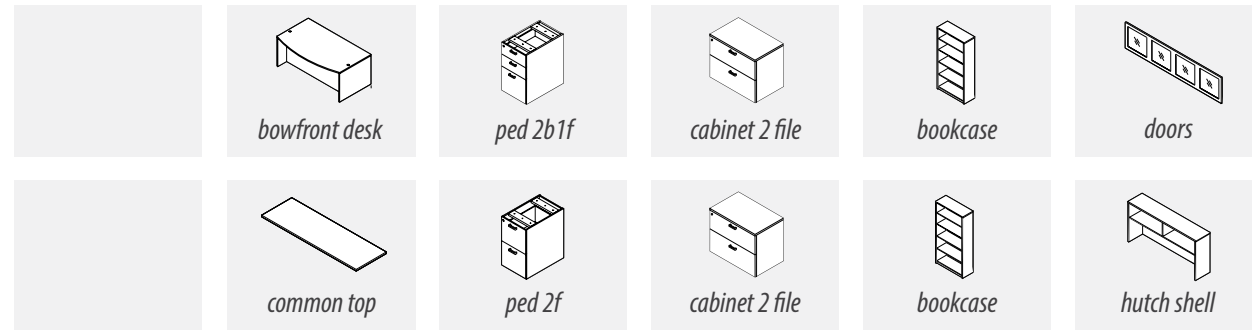
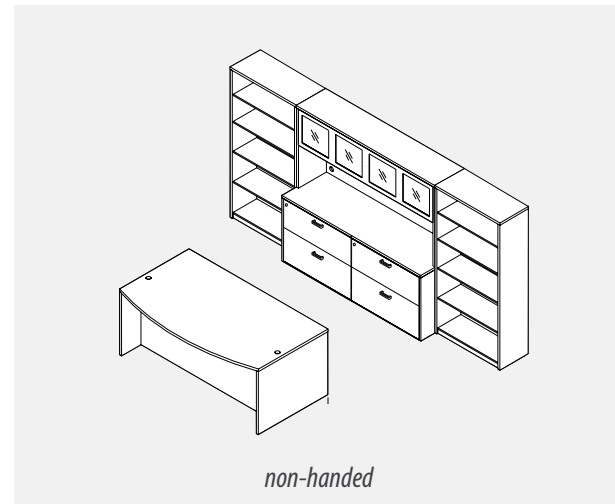

Product Code		D	W	H	Weight lbs.	Cubic ft.	Cartons	List Price
<b>AM-406N.MAHO</b>	desk	35½/41	71	29	180	6.14	1	<b>\$5,896</b>
<b>AM-406N.BLKC</b>	ped 2b1f	22	15½	28	86	7.63	1	
<b>AM-406N.WLNT</b>	ped 2f	22	15½	28	78	7.63	1	
<b>AM-406N.GREY</b>	top	22½	71	1	46	1.00	1	
	cabinet 2f	23	35½	29	148	16.83	1	
	cabinet 2f	23	35½	29	148	16.83	1	
	bookcase	15	35½	65	172	5.79	1	
	bookcase	15	35½	65	172	5.79	1	
	hutch shell	15	71	36	123	5.30		
	doors aluminum frame glass	¾	69¼	15	21	1.24		

### ACCESSORY

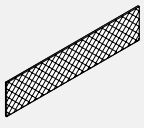
Tackboard	Product Code	D	W	H	Weight lbs.	Cubic ft.	Cartons	List Price
	<b>A201.LIGHT</b>	1½	68	18	10	1.05	1	<b>\$200</b>

*used with hutch A426*



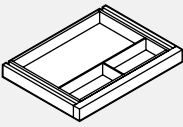

### ACCESSORY

Center Drawer	Product Code	D	W	H	Weight lbs.	Cubic ft.	Cartons	List Price
	<b>A830.MAHO</b>	14	20	2	9	0.59	1	<b>\$72</b>
	<b>A830.BLKC</b>							
	<b>A830.WLNT</b>							
	<b>A830.GREY</b>							

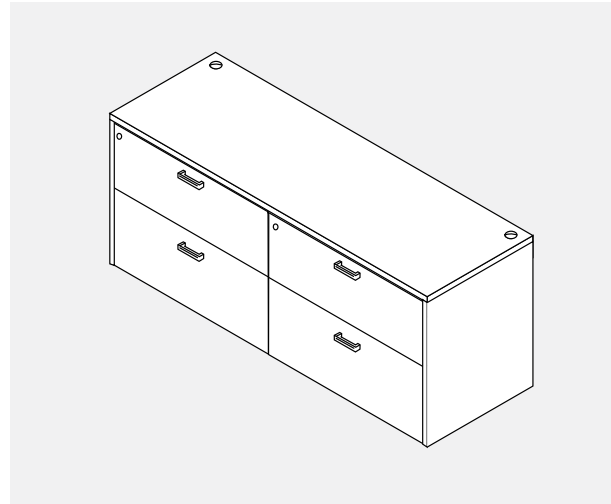
# CREDENZA

Cabinets  
2 File / 2 File





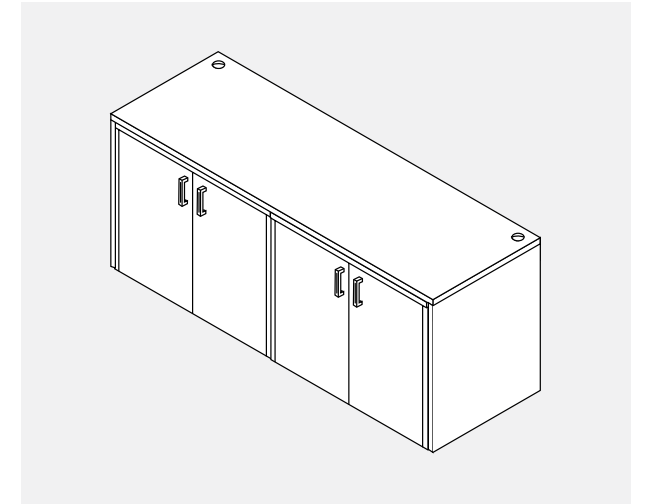

Product Code		D	W	H	Weight lbs.	Cubic ft.	Cartons	List Price
<b>AM-377N.MAHO</b>	 <i>top</i>	22½	71	1	46	1.00	1	<b>\$2,120</b>
<b>AM-377N.BLKC</b>	 <i>cabinet 2f</i>	22½	35½	29	148	16.83	1	
<b>AM-377N.WLNT</b>	 <i>cabinet 2f</i>	22½	35½	29	148	16.83	1	
<b>AM-377N.GREY</b>								

# CREDENZA

Cabinets  
2 Door / 2 Door



Product Code		D	W	H	Weight lbs.	Cubic ft.	Cartons	List Price
<b>AM-394N.MAHO</b>	 <i>top</i>	22½	71	1	46	1.00	1	<b>\$1,192</b>
<b>AM-394N.BLKC</b>	 <i>cabinet 2d</i>	22½	35½	29	148	16.83	1	
<b>AM-394N.WLNT</b>	 <i>cabinet 2d</i>	22½	35½	29	148	16.83	1	
<b>AM-394N.GREY</b>								

# CREDENZA

Kneespace

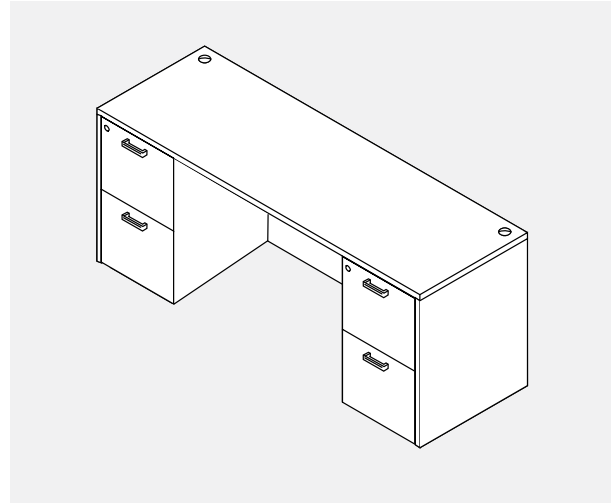

Product Code		D	W	H	Weight lbs.	Cubic ft.	Cartons	List Price
<b>AM-307N.MAHO</b>	credenza	24	<b>66</b>	29	115	3.96	1	<b>\$1,416</b>
<b>AM-307N.BLKC</b>	ped 2f	22	15½	28	78	7.63	1	
<b>AM-307N.WLNT</b>	ped 2f	22	15½	28	78	7.63	1	
<b>AM-307N.GREY</b>								
<b>AM-308N.MAHO</b>	credenza	24	<b>71</b>	29	122	4.29	1	<b>\$1,444</b>
<b>AM-308N.BLKC</b>	ped 2f	22	15½	28	78	7.63	1	
<b>AM-308N.WLNT</b>	ped 2f	22	15½	28	78	7.63	1	
<b>AM-308N.GREY</b>								

# CREDENZA

Kneespace  
Pedestals  
Suspended

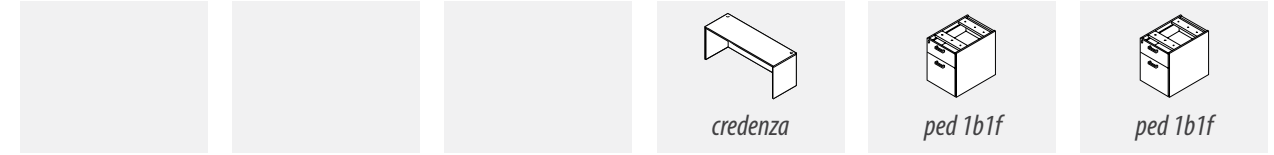
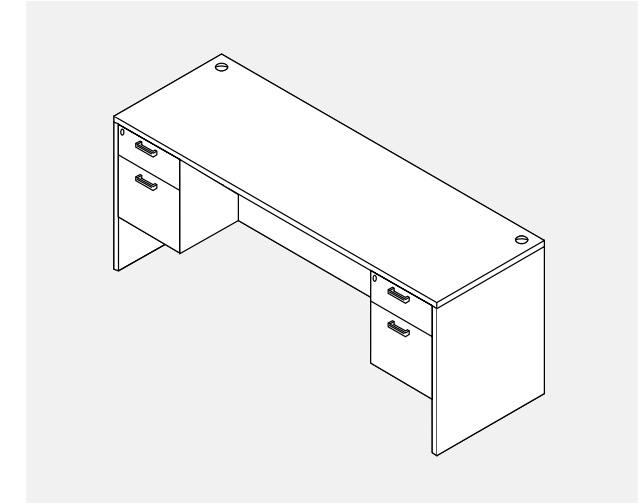

Product Code		D	W	H	Weight lbs.	Cubic ft.	Cartons	List Price
<b>AM-309N.MAHO</b>	credenza	24	<b>66</b>	29	115	3.96	1	<b>\$1,224</b>
<b>AM-309N.BLKC</b>	ped 1b1f	22	15½	20	78	5.82	1	
<b>AM-309N.WLNT</b>	ped 1b1f	22	15½	20	78	5.82	1	
<b>AM-309N.GREY</b>								
<b>AM-310N.MAHO</b>	credenza	24	<b>71</b>	29	122	4.29	1	<b>\$1,252</b>
<b>AM-310N.BLKC</b>	ped 1b1f	22	15½	20	78	5.82	1	
<b>AM-310N.WLNT</b>	ped 1b1f	22	15½	20	78	5.82	1	
<b>AM-310N.GREY</b>								

# L-DESKS

AMBER TYPICALS



SHOWN: AM-312N.WLNT  
L-Desk Rectangular

## L-DESK Bowfront

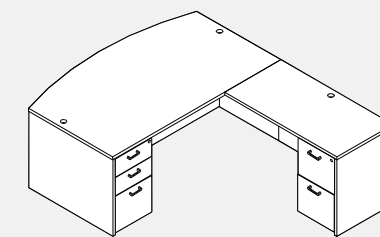

non-handed

Product Code		D	W	H	Weight lbs.	Cubic ft.	Cartons	List Price
<b>AM-321N.MAHO</b>	desk	35½/41	71	29	180	6.14	1	<b>\$2,056</b>
<b>AM-321N.BLKC</b>	ped 2b1f	22	15½	28	86	7.63	1	
<b>AM-321N.WLNT</b>	return	<b>24</b>	<b>42</b>	29	82	2.90	1	
<b>AM-321N.GREY</b>	ped 2f	22	15½	28	78	7.63	1	
<b>AM-322N.MAHO</b>	desk	35½/41	71	29	180	6.14	1	<b>\$2,104</b>
<b>AM-322N.BLKC</b>	ped 2b1f	22	15½	28	86	7.63	1	
<b>AM-322N.WLNT</b>	return	<b>24</b>	<b>48</b>	29	104	3.22	1	
<b>AM-322N.GREY</b>	ped 2f	22	15½	28	78	7.63	1	

## L-DESK Bowfront Pedestals Suspended

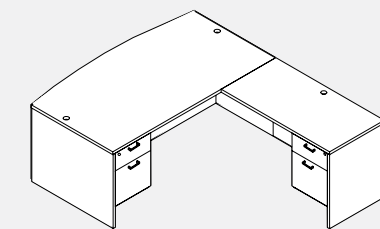

non-handed

Product Code		D	W	H	Weight lbs.	Cubic ft.	Cartons	List Price
<b>AM-323N.MAHO</b>	desk	35½/41	71	29	180	6.14	1	<b>\$1,800</b>
<b>AM-323N.BLKC</b>	ped 1b1f	22	15½	20	62	5.82	1	
<b>AM-323N.WLNT</b>	return	<b>24</b>	<b>42</b>	29	82	2.90	1	
<b>AM-323N.GREY</b>	ped 1b1f	22	15½	20	62	5.82	1	
<b>AM-324N.MAHO</b>	desk	35½/41	71	29	180	6.14	1	<b>\$1,848</b>
<b>AM-324N.BLKC</b>	ped 1b1f	22	15½	20	62	5.82	1	
<b>AM-324N.WLNT</b>	return	<b>24</b>	<b>48</b>	29	104	3.22	1	
<b>AM-324N.GREY</b>	ped 1b1f	22	15½	20	62	5.82	1	

# L-DESK

## Rectangular

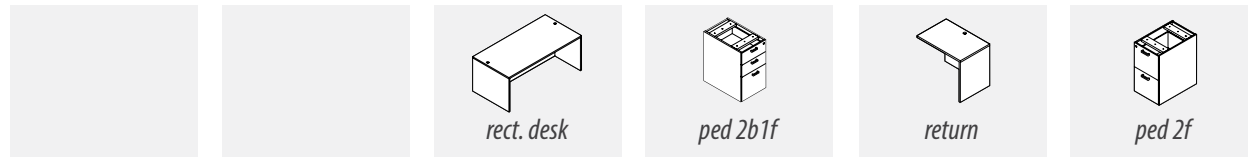
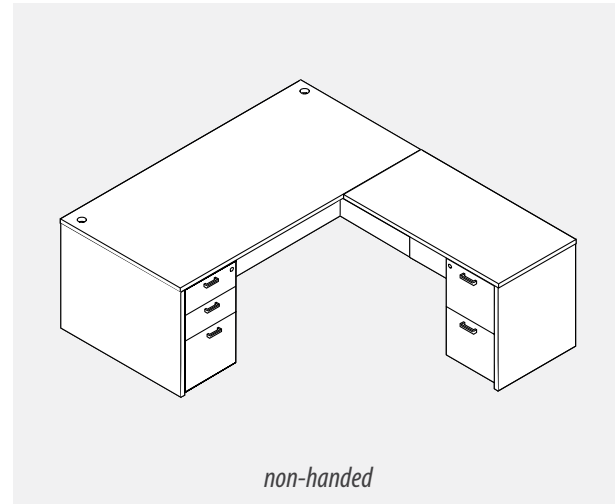

Product Code		D	W	H	Weight lbs.	Cubic ft.	Cartons	List Price
<b>AM-312N.MAHO</b>	desk	<b>30</b>	<b>66</b>	29	126	4.27	1	<b>\$1,880</b>
<b>AM-312N.BLKC</b>	ped 2b1f	22	15½	28	86	7.63	1	
<b>AM-312N.WLNT</b>	return	24	<b>42</b>	29	82	2.90	1	
<b>AM-312N.GREY</b>	ped 2f	22	15½	28	78	7.63	1	
<b>AM-313N.MAHO</b>	desk	<b>30</b>	<b>66</b>	29	126	4.27	1	<b>\$1,928</b>
<b>AM-313N.BLKC</b>	ped 2b1f	22	15½	28	86	7.63	1	
<b>AM-313N.WLNT</b>	return	24	<b>48</b>	29	104	3.22	1	
<b>AM-313N.GREY</b>	ped 2f	22	15½	28	78	7.63	1	
<b>AM-417N.MAHO</b>	desk	<b>30</b>	<b>71</b>	29	130	4.41	1	<b>\$2,000</b>
<b>AM-417N.BLKC</b>	ped 2b1f	22	15½	28	86	7.63	1	
<b>AM-417N.WLNT</b>	return	24	<b>42</b>	29	82	2.90	1	
<b>AM-417N.GREY</b>	ped 2f	22	15½	28	78	7.63	1	

# L-DESK

## Rectangular

[Continuation]

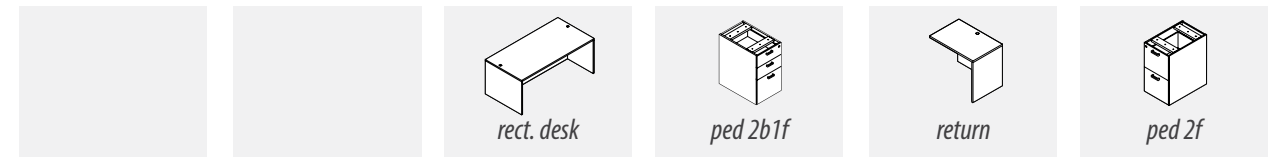
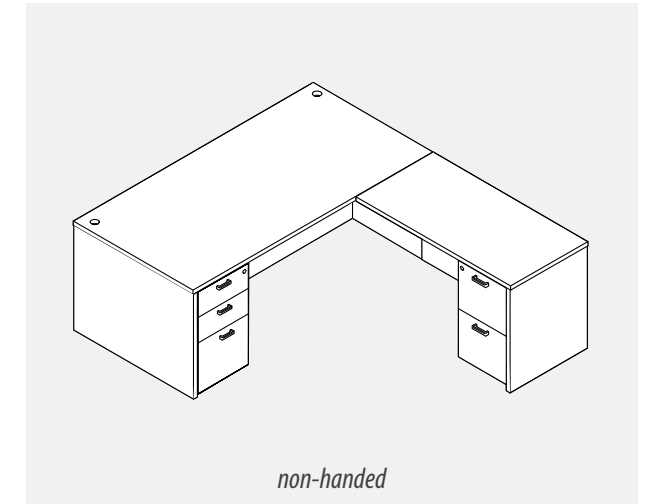

Product Code		D	W	H	Weight lbs.	Cubic ft.	Cartons	List Price
<b>AM-418N.MAHO</b>	desk	<b>30</b>	<b>71</b>	29	130	4.41	1	<b>\$2,048</b>
<b>AM-418N.BLKC</b>	ped 2b1f	22	15½	28	86	7.63	1	
<b>AM-418N.WLNT</b>	return	24	<b>48</b>	29	104	3.22	1	
<b>AM-418N.GREY</b>	ped 2f	22	15½	28	78	7.63	1	
<b>AM-314N.MAHO</b>	desk	<b>36</b>	<b>71</b>	29	150	5.34	1	<b>\$2,000</b>
<b>AM-314N.BLKC</b>	ped 2b1f	22	15½	28	86	7.63	1	
<b>AM-314N.WLNT</b>	return	24	<b>42</b>	29	104	3.22	1	
<b>AM-314N.GREY</b>	ped 2f	22	15½	28	78	7.63	1	
<b>AM-315N.MAHO</b>	desk	<b>36</b>	<b>71</b>	29	150	5.34	1	<b>\$2,048</b>
<b>AM-315N.BLKC</b>	ped 2b1f	22	15½	28	86	7.63	1	
<b>AM-315N.WLNT</b>	return	24	<b>48</b>	29	82	2.90	1	
<b>AM-315N.GREY</b>	ped 2f	22	15½	28	78	7.63	1	

# L-DESK

Rectangular  
Pedestals Suspended

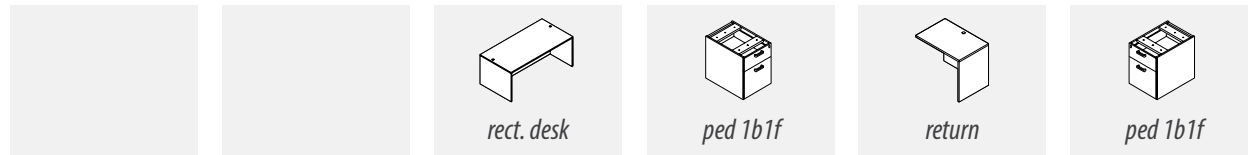
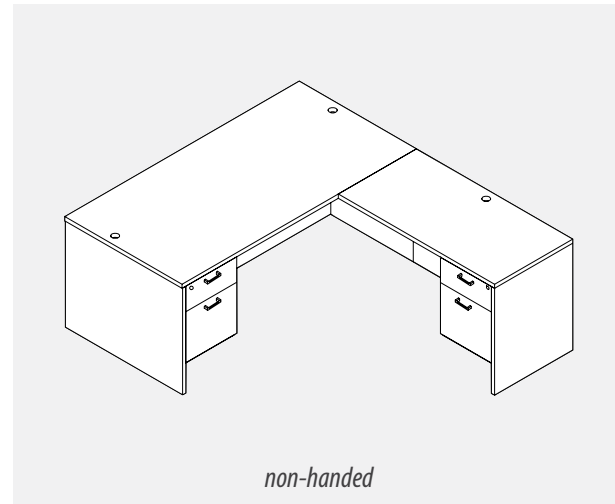

Product Code		D	W	H	Weight lbs.	Cubic ft.	Cartons	List Price
<b>AM-316N.MAHO</b>	desk	<b>30</b>	<b>60</b>	29	112	3.89	1	<b>\$1,552</b>
<b>AM-316N.BLKC</b>	ped 1b1f	22	15½	20	62	5.82	1	
<b>AM-316N.WLNT</b>	return	20	<b>42</b>	29	82	2.90	1	
<b>AM-316N.GREY</b>	ped 1b1f	18	15½	20	62	5.82	1	
<b>AM-317N.MAHO</b>	desk	<b>30</b>	<b>66</b>	29	126	5.34	1	<b>\$1,624</b>
<b>AM-317N.BLKC</b>	ped 1b1f	22	15½	20	62	5.82	1	
<b>AM-317N.WLNT</b>	return	24	<b>42</b>	29	82	2.90	1	
<b>AM-317N.GREY</b>	ped 1b1f	22	15½	20	62	5.82	1	
<b>AM-318N.MAHO</b>	desk	<b>30</b>	<b>66</b>	29	126	5.34	1	<b>\$1,672</b>
<b>AM-318N.BLKC</b>	ped 1b1f	22	15½	20	62	5.82	1	
<b>AM-318N.WLNT</b>	return	24	<b>48</b>	29	104	3.22	1	
<b>AM-318N.GREY</b>	ped 1b1f	22	15½	20	62	5.82	1	
<b>AM-419N.MAHO</b>	desk	<b>30</b>	<b>71</b>	29	130	4.41	1	<b>\$1,744</b>
<b>AM-419N.BLKC</b>	ped 1b1f	22	15½	20	62	5.82	1	
<b>AM-419N.WLNT</b>	return	24	<b>42</b>	29	82	2.90	1	
<b>AM-419N.GREY</b>	ped 1b1f	22	15½	20	62	5.82	1	

# L-DESK

Rectangular  
Pedestals Suspended  
*[Continuation]*

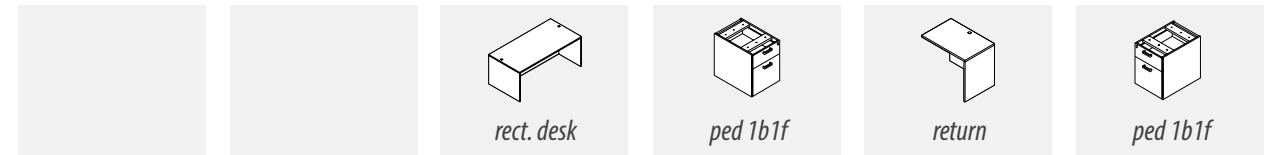
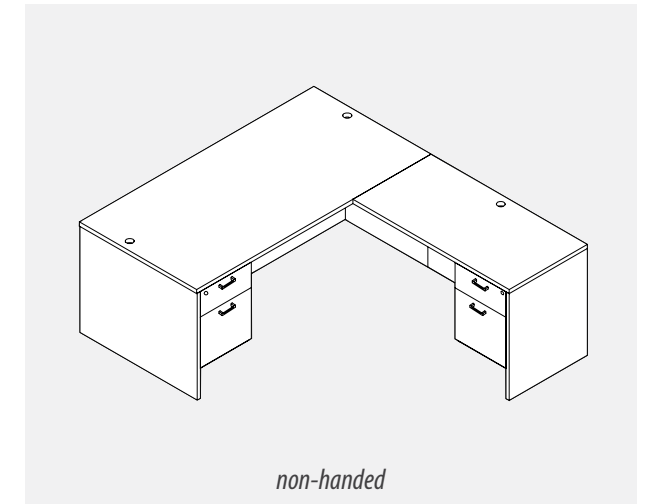

Product Code		D	W	H	Weight lbs.	Cubic ft.	Cartons	List Price
<b>AM-420N.MAHO</b>	desk	<b>30</b>	<b>71</b>	29	130	4.41	1	<b>\$1,792</b>
<b>AM-420N.BLKC</b>	ped 1b1f	22	15½	20	62	5.82	1	
<b>AM-420N.WLNT</b>	return	24	<b>48</b>	29	104	3.22	1	
<b>AM-420N.GREY</b>	ped 1b1f	22	15½	20	62	5.82	1	
<b>AM-319N.MAHO</b>	desk	<b>36</b>	<b>71</b>	29	150	5.34	1	<b>\$1,744</b>
<b>AM-319N.BLKC</b>	ped 1b1f	22	15½	20	62	5.82	1	
<b>AM-319N.WLNT</b>	return	24	<b>42</b>	29	82	2.90	1	
<b>AM-319N.GREY</b>	ped 1b1f	22	15½	20	62	5.82	1	
<b>AM-320N.MAHO</b>	desk	<b>36</b>	<b>71</b>	29	150	5.34	1	<b>\$1,792</b>
<b>AM-320N.BLKC</b>	ped 1b1f	22	15½	20	62	5.82	1	
<b>AM-320N.WLNT</b>	return	24	<b>48</b>	29	104	3.22	1	
<b>AM-320N.GREY</b>	ped 1b1f	22	15½	20	62	5.82	1	

# U-DESKS

AMBER TYPICALS









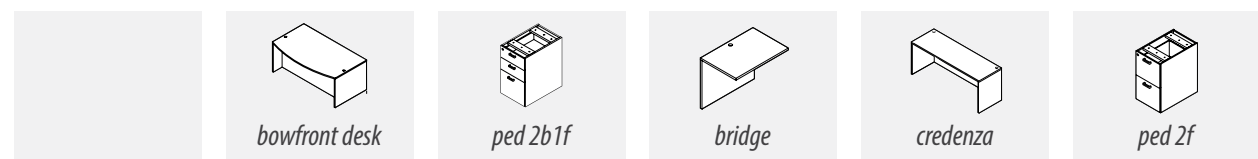
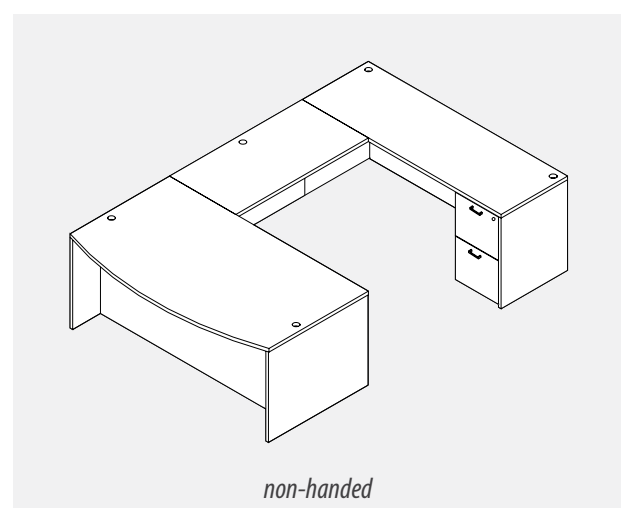



SHOWN: AM-421N.WLNT  
U-Desk Rectangular Pedestals

## U-DESK

### Bowfront Pedestals



Product Code		D	W	H	Weight lbs.	Cubic ft.	Cartons	List Price
<b>AM-354N.MAHO</b>	 desk	35½/41	71	29	180	6.14	1	<b>\$2,416</b>
<b>AM-354N.BLKC</b>	 ped 2b1f	22	15½	28	86	7.63	1	
<b>AM-354N.WLNT</b>	 bridge	<b>24</b>	<b>42</b>	29	67	2.08	1	
<b>AM-354N.GREY</b>	 credenza	24	71	29	122	4.29	1	
	 ped 2f	22	15½	28	78	7.63	1	
<b>AM-355N.MAHO</b>	 desk	35½/41	71	29	180	6.14	1	<b>\$2,452</b>
<b>AM-355N.BLKC</b>	 ped 2b1f	22	15½	28	86	7.63	1	
<b>AM-355N.WLNT</b>	 bridge	<b>24</b>	<b>48</b>	29	75	2.35	1	
<b>AM-355N.GREY</b>	 credenza	24	71	29	122	4.29	1	
	 ped 2f	22	15½	28	78	7.63	1	

# U-DESK

## Rectangular Pedestals

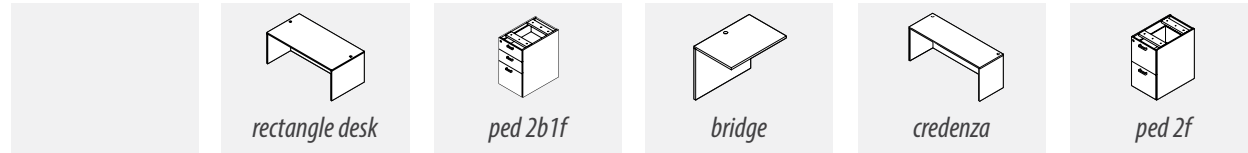
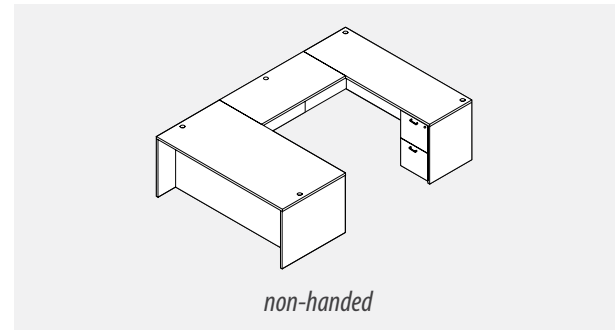

Product Code		D	W	H	Weight lbs.	Cubic ft.	Cartons	List Price
<b>AM-421N.MAHO</b>	desk	<b>30</b>	<b>71</b>	29	130	4.41	1	<b>\$2,360</b>
<b>AM-421N.BLKC</b>	ped 2b1f	22	15½	28	86	7.63	1	
<b>AM-421N.WLNT</b>	bridge	<b>24</b>	<b>42</b>	29	67	2.08	1	
<b>AM-421N.GREY</b>	credenza	24	71	29	122	4.29	1	
	ped 2f	22	15½	28	78	7.63	1	
<hr/>								
<b>AM-349N.MAHO</b>	desk	<b>36</b>	<b>71</b>	29	150	5.34	1	<b>\$2,360</b>
<b>AM-349N.BLKC</b>	ped 2b1f	22	15½	28	86	7.63	1	
<b>AM-349N.WLNT</b>	bridge	<b>24</b>	<b>42</b>	29	67	2.08	1	
<b>AM-349N.GREY</b>	credenza	24	71	29	122	4.29	1	
	ped 2f	22	15½	28	78	7.63	1	
<hr/>								
<b>AM-422N.MAHO</b>	desk	<b>30</b>	<b>71</b>	29	130	4.41	1	<b>\$2,396</b>
<b>AM-422N.BLKC</b>	ped 2b1f	22	15½	28	86	7.63	1	
<b>AM-422N.WLNT</b>	bridge	<b>24</b>	<b>48</b>	29	75	2.35	1	
<b>AM-422N.GREY</b>	credenza	24	71	29	122	4.29	1	
	ped 2f	22	15½	28	78	7.63	1	
<hr/>								
<b>AM-350N.MAHO</b>	desk	<b>36</b>	<b>71</b>	29	150	5.34	1	<b>\$2,396</b>
<b>AM-350N.BLKC</b>	ped 2b1f	22	15½	28	86	7.63	1	
<b>AM-350N.WLNT</b>	bridge	<b>24</b>	<b>48</b>	29	75	2.35	1	
<b>AM-350N.GREY</b>	credenza	24	71	29	122	4.29	1	
	ped 2f	22	15½	28	78	7.63	1	

# U-DESK

## Rectangular Pedestals + Lateral File

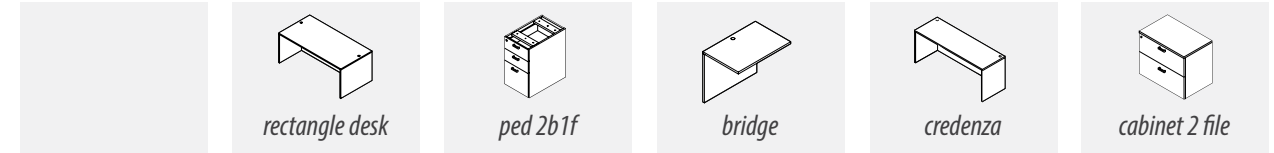
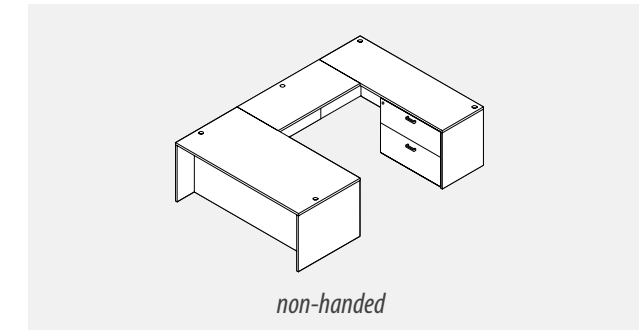

Product Code		D	W	H	Weight lbs.	Cubic ft.	Cartons	List Price
<b>AM-423N.MAHO</b>	desk	<b>30</b>	<b>71</b>	29	130	4.41	1	<b>\$2,808</b>
<b>AM-423N.BLKC</b>	ped 2b1f	22	15½	28	86	7.63	1	
<b>AM-423N.WLNT</b>	bridge	<b>24</b>	<b>42</b>	29	67	2.08	1	
<b>AM-423N.GREY</b>	credenza	24	71	29	122	4.29	1	
	cabinet 2 file	23	35½	28	148	16.83	1	
<hr/>								
<b>AM-351N.MAHO</b>	desk	<b>36</b>	<b>71</b>	29	150	5.34	1	<b>\$2,808</b>
<b>AM-351N.BLKC</b>	ped 2b1f	22	15½	28	86	7.63	1	
<b>AM-351N.WLNT</b>	bridge	<b>24</b>	<b>42</b>	29	67	2.08	1	
<b>AM-351N.GREY</b>	credenza	24	71	29	122	4.29	1	
	cabinet 2f	23	35½	28	148	16.83	1	
<hr/>								
<b>AM-424N.MAHO</b>	desk	<b>30</b>	<b>71</b>	29	130	4.41	1	<b>\$2,844</b>
<b>AM-424N.BLKC</b>	ped 2b1f	22	15½	28	86	7.63	1	
<b>AM-424N.WLNT</b>	bridge	<b>24</b>	<b>48</b>	29	75	2.35	1	
<b>AM-424N.GREY</b>	credenza	24	71	29	122	4.29	1	
	cabinet 2f	23	35½	28	148	16.83	1	
<hr/>								
<b>AM-352N.MAHO</b>	desk	<b>36</b>	<b>71</b>	29	150	5.34	1	<b>\$2,844</b>
<b>AM-352N.BLKC</b>	ped 2b1f	22	15½	28	86	7.63	1	
<b>AM-352N.WLNT</b>	bridge	<b>24</b>	<b>48</b>	29	75	2.35	1	
<b>AM-352N.GREY</b>	credenza	24	71	29	122	4.29	1	
	cabinet 2f	23	35½	28	148	16.83	1	



# U-DESK

Bowfront  
Pedestals +  
Cabinet 2 File

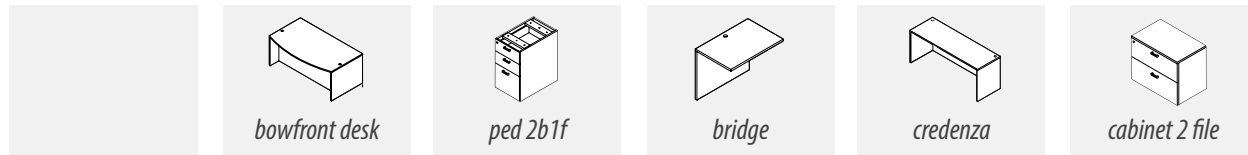
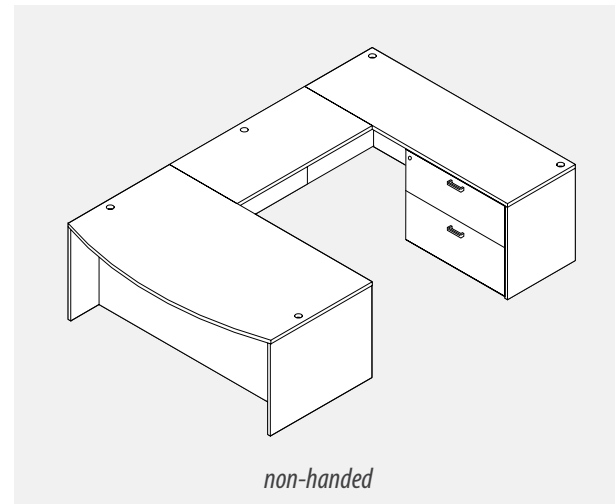

Product Code		D	W	H	Weight lbs.	Cubic ft.	Cartons	List Price
<b>AM-356N.MAHO</b>	desk	35½/41	71	29	180	6.14	1	<b>\$2,864</b>
<b>AM-356N.BLKC</b>	ped 2b1f	22	15½	28	86	7.63	1	
<b>AM-356N.WLNT</b>	bridge	<b>24</b>	<b>42</b>	29	67	2.08	1	
<b>AM-356N.GREY</b>	credenza	24	71	29	122	4.29	1	
	cabinet 2f	23	35½	28	148	16.83	1	
<b>AM-357N.MAHO</b>	desk	35½/41	71	29	180	6.14	1	<b>\$2,900</b>
<b>AM-357N.BLKC</b>	ped 2b1f	22	15½	28	86	7.63	1	
<b>AM-357N.WLNT</b>	bridge	<b>24</b>	<b>48</b>	29	75	2.35	1	
<b>AM-357N.GREY</b>	credenza	24	71	29	122	4.29	1	
	cabinet 2f	23	35½	28	148	16.83	1	

# U-DESK

Configuration

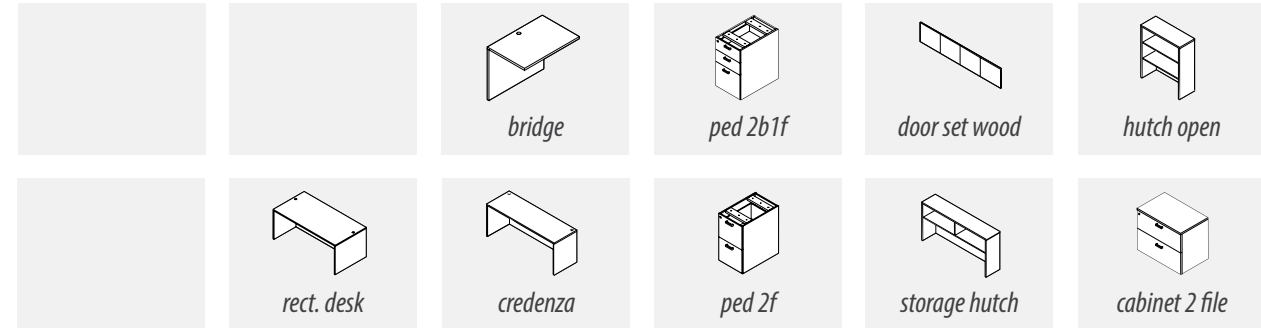
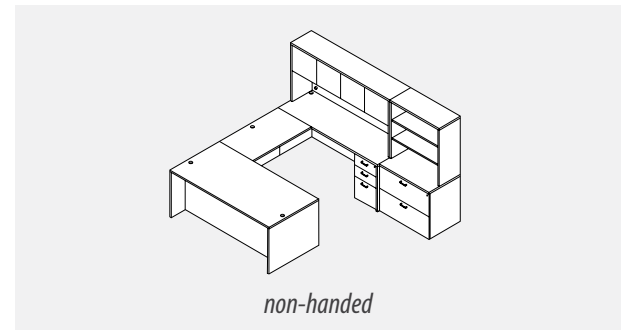

Product Code		D	W	H	Weight lbs.	Cubic ft.	Cartons	List Price
<b>AM-426N.MAHO</b>	desk	<b>30</b>	<b>71</b>	29	130	4.41	1	<b>\$4,316</b>
<b>AM-426N.BLKC</b>	ped 2b1f	22	15½	28	86	7.63	1	
<b>AM-426N.WLNT</b>	bridge	24	48	29	75	2.35	1	
<b>AM-426N.GREY</b>	credenza	24	71	29	139	5.34	1	
	ped 2f	22	15½	28	78	7.63	1	
	hutch shell	15	71	36	123	5.30	1	
	doors	¾	69¼	15	22	1.24	1	
	cabinet 2f	23	35½	29	148	16.83	1	
	hutch	14	35½	36	95	3.39	1	
<b>AM-405N.MAHO</b>	desk	<b>36</b>	<b>71</b>	29	150	5.34	1	<b>\$4,316</b>
<b>AM-405N.BLKC</b>	ped 2b1f	22	15½	28	86	7.63	1	
<b>AM-405N.WLNT</b>	bridge	24	48	29	75	2.35	1	
<b>AM-405N.GREY</b>	credenza	24	71	29	139	5.34	1	
	ped 2f	22	15½	28	78	7.63	1	
	hutch shell	15	71	36	123	5.30	1	
	doors	¾	69¼	15	22	1.24	1	
	cabinet 2f	23	35½	29	148	16.83	1	
	hutch	14	35½	36	95	3.39	1	

# RECEPTION

AMBER TYPICALS









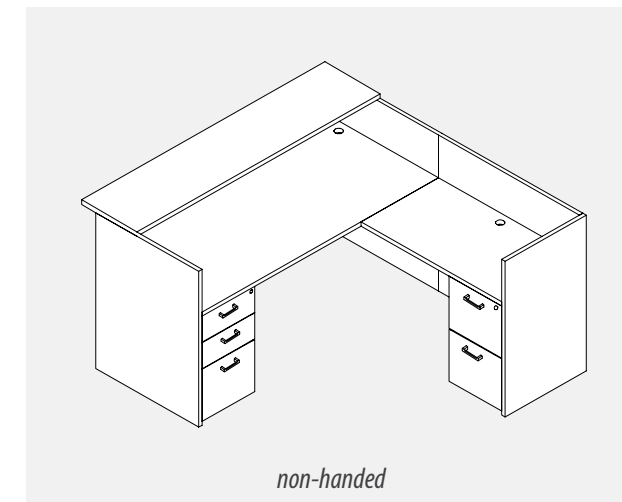

SHOWN: AM-404N.GREY  
Dual Station Reception w/Glass Transaction Top  
SHOWN: Qty 2 AM-394N.GREY  
Credenza Storage Cabinet

## L-DESK

Reception with Transaction Top



Product Code		D	W	H	Weight lbs.	Cubic ft.	Cartons	List Price
<b>AM-399N.MAHO</b>	 desk	36	71	42	210	6.94	1	<b>\$2,272</b>
<b>AM-399N.BLKC</b>	 return	24	42	42	103	3.30	1	
<b>AM-399N.WLNT</b>	 ped 2b1f	22	15½	28	86	7.63	1	
<b>AM-399N.GREY</b>	 ped 2f	22	15½	28	78	7.63	1	
	 top	15	71	½	75	2.25	1	
<b>AM-400N.MAHO</b>								<b>\$2,672</b>
<b>AM-400N.BLKC</b>								
<b>AM-400N.WLNT</b>								
<b>AM-400N.GREY</b>								
	includes Glass Transaction Top	15	71	½	210	6.94	1	

# L-DESK

Reception with Transaction Top  
Pedestals Suspended

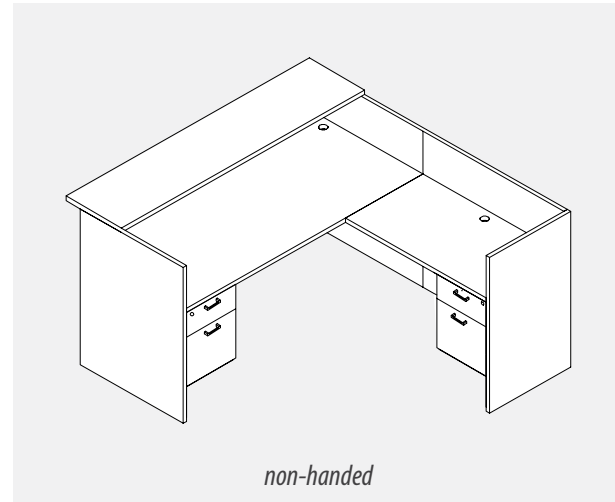

Product Code		D	W	H	Weight lbs.	Cubic ft.	Cartons	List Price
<b>AM-401N.MAHO</b>	desk	36	71	42	210	6.94	1	<b>\$2,016</b>
<b>AM-401N.BLKC</b>	return	24	42	42	103	3.30	1	
<b>AM-401N.WLNT</b>	ped 1b1f	22	15½	20	62	5.82	1	
<b>AM-401N.GREY</b>	ped 1b1f	22	15½	20	62	5.82	1	
	top	15	71	½	75	2.25	1	
<b>AM-402N.MAHO</b>								<b>\$2,416</b>
<b>AM-402N.BLKC</b>								
<b>AM-402N.WLNT</b>								
<b>AM-402N.GREY</b>								
	includes Glass Transaction Top	15	71	½	210	6.94	1	

# DUAL STATION

Reception with Glass  
Transaction Top

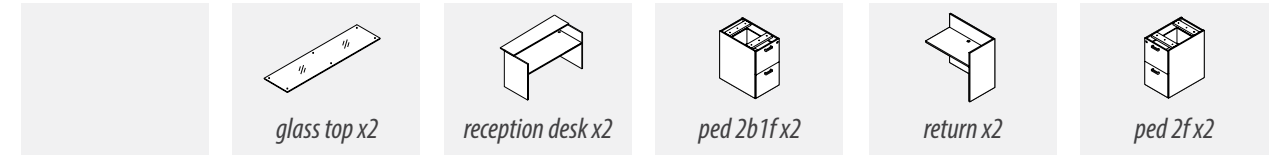
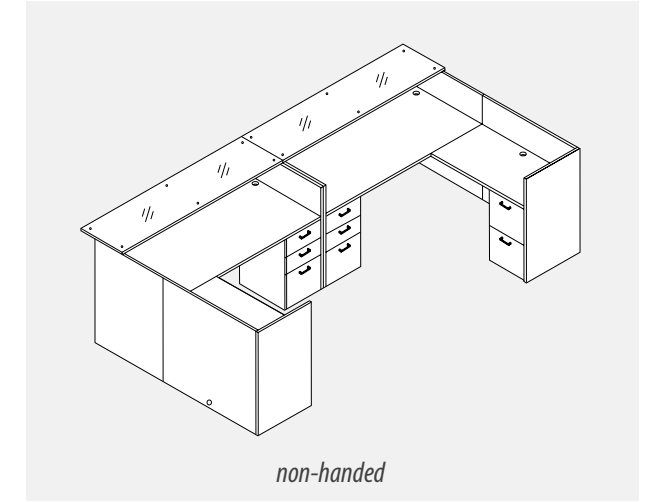

Product Code		D	W	H	Weight lbs.	Cubic ft.	Cartons	List Price
<b>AM-403N.MAHO</b>	desk	36	71	42	210	6.94	1	<b>\$4,544</b>
<b>AM-403N.BLKC</b>	desk	36	71	42	210	6.94	1	
<b>AM-403N.WLNT</b>	return	24	42	42	206	3.30	1	
<b>AM-403N.GREY</b>	return	24	42	42	206	3.30	1	
	ped 2b1f	22	15½	28	86	7.63	1	
	ped 2b1f	22	15½	28	86	7.63	1	
	ped 2f	22	15½	28	78	7.63	1	
	ped 2f	22	15½	28	78	7.63	1	
	top	15	71	½	75	2.25	1	
	top	15	71	½	75	2.25	1	

<b>AM-404N.MAHO</b>								<b>\$5,344</b>
<b>AM-404N.BLKC</b>								
<b>AM-404N.WLNT</b>								
<b>AM-404N.GREY</b>								
	includes Glass Transaction Top	15	71	½	210	6.94	1	
	includes Glass Transaction Top	15	71	½	210	6.94	1	

# TABLES

AMBER TYPICALS



SHOWN: AM-720N.WLNT  
Conference Table Racetrack

## TABLE

Conference Round	Product Code	D	W	H	Weight lbs.	Cubic ft.	Cartons	List Price
	A722.MAHO	36	36	29	80	2.04	1	\$426
	A722.BLKC							
	A722.WLNT							
	A722.GREY							

## TABLE

Conference Racetrack	Product Code	D	W	H	Weight lbs.	Cubic ft.	Cartons	List Price
	A720.MAHO	35	71	29	135	5.57	1	\$620
	A720.BLKC							
	A720.WLNT							
	A720.GREY							
	A723.MAHO	42	95	29	190	5.53	1	\$800
	A723.BLKC							
	A723.WLNT							
	A723.GREY							

## TABLE

Conference Expandable	Product Code	D	W	H	Weight lbs.	Cubic ft.	Cartons	List Price
	AM408.MAHO	48	120	29	257	10.21	2	\$1,480
	AM408.BLKC							
	AM408.WLNT							
	AM408.GREY							
	AM409.MAHO	48	144	29	294	11.58	2	\$1,840
	AM409.BLKC							
	AM409.WLNT							
	AM409.GREY							









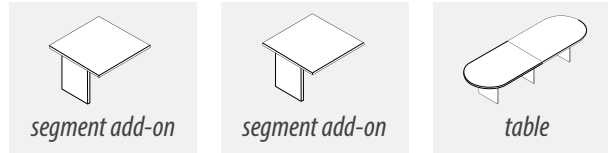
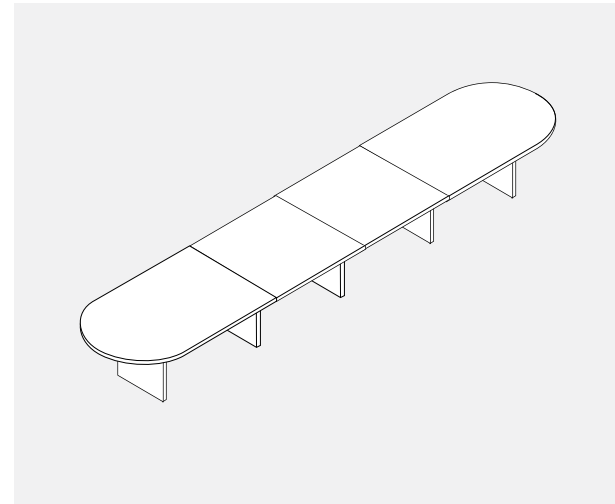





## TABLE

Segment Add-On	Product Code	D	W	H	Weight lbs.	Cubic ft.	Cartons	List Price
	A739.MAHO	48	48	29	103	4.92	1	\$600
	A739.BLKC							
	A739.WLNT							
	A739.GREY							

# TABLE

## Conference Expandable









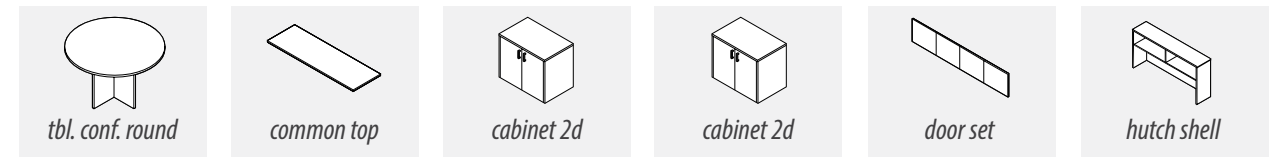
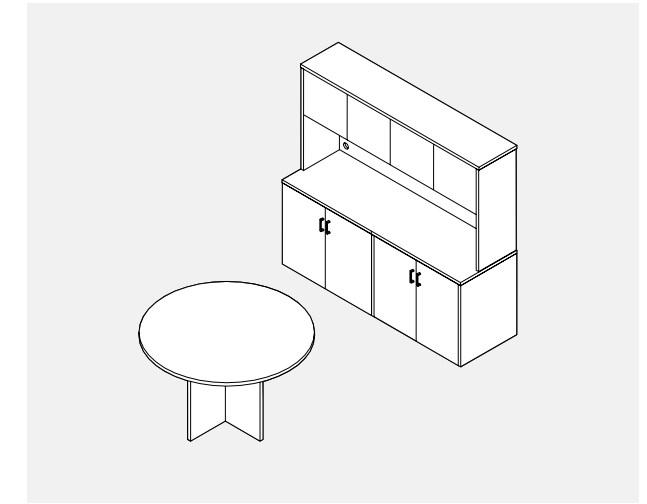



Product Code		D	W	H	Weight lbs.	Cubic ft.	Cartons	List Price
<b>AM-410N.MAHO</b>	 120" table	48	<b>168</b>	29	360	15.13	3	<b>\$2,080</b>
<b>AM-410N.BLKC</b>	 48" segment							
<b>AM-410N.WLNT</b>								
<b>AM-410N.GREY</b>								
<b>AM-411N.MAHO</b>	 144" table	48	<b>192</b>	29	397	16.50	3	<b>\$2,440</b>
<b>AM-411N.BLKC</b>	 48" segment							
<b>AM-411N.WLNT</b>								
<b>AM-411N.GREY</b>								
<b>AM-412N.MAHO</b>	 120" table	48	<b>216</b>	29	463	20.05	4	<b>\$2,680</b>
<b>AM-412N.BLKC</b>	 48" segment							
<b>AM-412N.WLNT</b>	 48" segment							
<b>AM-412N.GREY</b>								
<b>AM-413N.MAHO</b>	 144" table	48	<b>240</b>	29	500	21.42	4	<b>\$3,040</b>
<b>AM-413N.BLKC</b>	 48" segment							
<b>AM-413N.WLNT</b>	 48" segment							
<b>AM-413N.GREY</b>								

# TABLE

## Meeting Configuration



Product Code		D	W	H	Weight lbs.	Cubic ft.	Cartons	List Price
<b>AM-378N.MAHO</b>	 top	22½	71	1	46	1.00	1	<b>\$2,242</b>
<b>AM-378N.BLKC</b>	 cabinet 2d	22½	35½	29	148	16.83	1	
<b>AM-378N.WLNT</b>	 cabinet 2d	22½	35½	29	148	16.83	1	
<b>AM-378N.GREY</b>	 table	36	36	29	80	2.04	1	
	 hutch shell	15	71	36	123	5.30	1	
	 doors	¾	69¼	15	22	1.24	1	
<b>AM-391N.MAHO</b>								<b>\$2,498</b>
<b>AM-391N.BLKC</b>								
<b>AM-391N.WLNT</b>								
<b>AM-391N.GREY</b>								
	<i>with doors aluminum frame glass</i>	¾	69¼	15	21	1.24	1	



## Components **AMBER**

Our office furniture suite provides exceptional versatility, adaptable conference tables, and a wide range of storage solutions to suit any workspace.

Each component is designed to seamlessly integrate, offering both functionality and aesthetic appeal for diverse office environments.

SHOWN  
AM-404N.GREY | 2 L-Desk Reception with Glass Transaction Top  
415W | Eon Series Task Chair Grey  
AM-394N.GREY | 2 Credenza 2D/2D

## DESK

Rectangle Shell

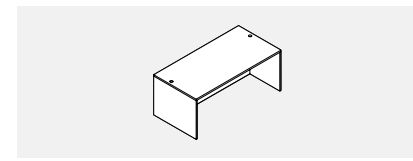

Product Code	D	W	H	Weight lbs.	Cubic ft.	Cartons	List Price
<b>A121.MAHO</b>	<b>30</b>	<b>60</b>	29	112	3.89	1	<b>\$440</b>
<b>A121.BLKC</b>							
<b>A121.WLNT</b>							
<b>A121.GREY</b>							
<b>A921.MAHO</b>	<b>30</b>	<b>66</b>	29	126	4.27	1	<b>\$480</b>
<b>A921.BLKC</b>							
<b>A921.WLNT</b>							
<b>A921.GREY</b>							
<b>A521.MAHO</b>	<b>30</b>	<b>71</b>	29	130	4.41	1	<b>\$600</b>
<b>A521.BLKC</b>							
<b>A521.WLNT</b>							
<b>A521.GREY</b>							
<b>A821.MAHO</b>	<b>36</b>	<b>71</b>	29	150	5.34	1	<b>\$600</b>
<b>A821.BLKC</b>							
<b>A821.WLNT</b>							
<b>A821.GREY</b>							

## DESK

Bowfront Shell

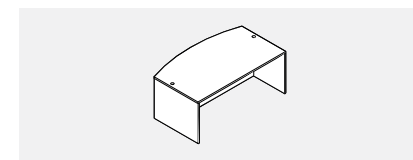

Product Code	D	W	H	Weight lbs.	Cubic ft.	Cartons	List Price
<b>A822.MAHO</b>	<b>35½/41</b>	<b>71</b>	29	180	6.14	1	<b>\$656</b>
<b>A822.BLKC</b>							
<b>A822.WLNT</b>							
<b>A822.GREY</b>							

## RECEPTION

Desk Shell

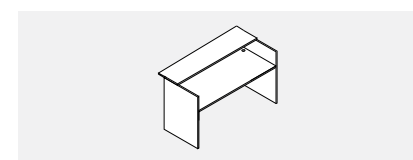

Product Code	D	W	H	Weight lbs.	Cubic ft.	Cartons	List Price
<b>A126.MAHO</b>	<b>36</b>	<b>71</b>	<b>42</b>	201	6.70	1	<b>\$800</b>
<b>A126.BLKC</b>							
<b>A126.WLNT</b>							
<b>A126.GREY</b>							

## DESK

Reception Glass Top

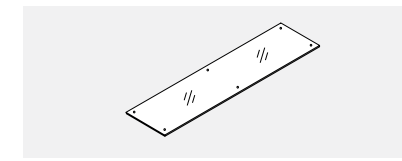

Product Code	D	W	H	Weight lbs.	Cubic ft.	Cartons	List Price
<b>A127</b>	<b>15</b>	<b>71</b>	<b>½</b>	75	2.40	1	<b>\$400</b>

## BRIDGE

Component

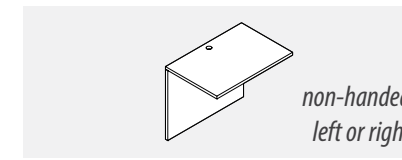

Product Code	D	W	H	Weight lbs.	Cubic ft.	Cartons	List Price
<b>A623.MAHO</b>	<b>24</b>	<b>35</b>	29	56	1.80	1	<b>\$232</b>
<b>A623.BLKC</b>							
<b>A623.WLNT</b>							
<b>A623.GREY</b>							
<b>A923.MAHO</b>	<b>24</b>	<b>42</b>	29	67	2.08	1	<b>\$252</b>
<b>A923.BLKC</b>							
<b>A923.WLNT</b>							
<b>A923.GREY</b>							
<b>A823.MAHO</b>	<b>24</b>	<b>48</b>	29	75	2.35	1	<b>\$288</b>
<b>A823.BLKC</b>							
<b>A823.WLNT</b>							
<b>A823.GREY</b>							

## RETURN

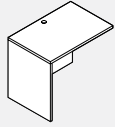
Shell	Product Code	D	W	H	Weight lbs.	Cubic ft.	Cartons	List Price
 <p>non-handed left or right</p>	A224.MAHO	20	42	29	78	2.88	1	\$304
	A224.BLKC							
	A224.WLNT							
	A224.GREY							
	A304.MAHO	24	30	29	58	2.04	1	\$256
	A304.BLKC							
	A304.WLNT							
	A304.GREY							
	A324.MAHO	24	35	29	70	2.46	1	\$288
	A324.BLKC							
	A324.WLNT							
	A324.GREY							
	A924.MAHO	24	42	29	82	2.90	1	\$312
	A924.BLKC							
	A924.WLNT							
	A924.GREY							
	A824.MAHO	24	48	29	104	3.22	1	\$360
	A824.BLKC							
	A824.WLNT							
	A824.GREY							

## RETURN

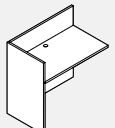
Reception Shell	Product Code	D	W	H	Weight lbs.	Cubic ft.	Cartons	List Price
 <p>non-handed left or right</p>	A124.MAHO	24	42	42	103	3.30	1	\$384
	A124.BLKC							
	A124.WLNT							
	A124.GREY							

## COMMON TOP

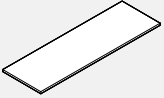
Storage Laterals 2f or 2d	Product Code	D	W	H	Weight lbs.	Cubic ft.	Cartons	List Price
	A425.MAHO	22½	71	1	46	1.00	1	\$200
	A425.BLKC							
	A425.WLNT							
	A425.GREY							

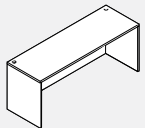

## CREDENZA

Component	Product Code	D	W	H	Weight lbs.	Cubic ft.	Cartons	List Price
 <p>left or right</p>	A925.MAHO	24	66	29	115	3.96	1	\$392
	A925.BLKC							
	A925.WLNT							
	A925.GREY							
	A825.MAHO	24	71	29	122	4.29	1	\$420
	A825.BLKC							
	A825.WLNT							
	A825.GREY							

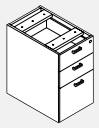
## STORAGE 2b1f

Ped Assembled	Product Code	D	W	H	Weight lbs.	Cubic ft.	Cartons	List Price
	A831.MAHO	22	15½	28	86	7.63	1	\$576
	A831.BLKC							
	A831.WLNT							
	A831.GREY							

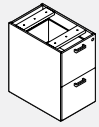
## STORAGE 2f

Ped Assembled	Product Code	D	W	H	Weight lbs.	Cubic ft.	Cartons	List Price
	A832.MAHO	22	15½	28	78	7.63	1	\$512
	A832.BLKC							
	A832.WLNT							
	A832.GREY							
 <p>for 20D Return</p>	A840.MAHO	18	15½	28	63	6.46	1	\$456
	A840.BLKC							
	A840.WLNT							
	A840.GREY							



### STORAGE 1b1f

Suspended Ped

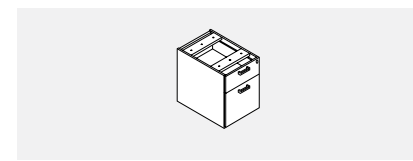

Product Code	D	W	H	Weight lbs.	Cubic ft.	Cartons	List Price
<b>A838.MAHO</b>	<b>22</b>	15½	20	62	5.82	1	<b>\$416</b>
<b>A838.BLKC</b>							
<b>A838.WLNT</b>							
<b>A838.GREY</b>							

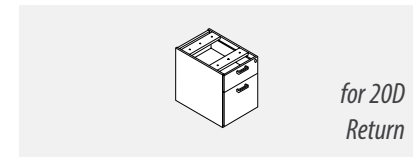

Product Code	D	W	H	Weight lbs.	Cubic ft.	Cartons	List Price
<b>A839.MAHO</b>	<b>18</b>	15½	20	56	4.93	1	<b>\$392</b>
<b>A839.BLKC</b>							
<b>A839.WLNT</b>							
<b>A839.GREY</b>							

### STORAGE CAB

2 Door

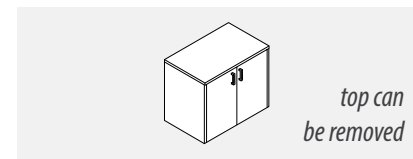

Product Code	D	W	H	Weight lbs.	Cubic ft.	Cartons	List Price
<b>A540.MAHO</b>	22½	35½	29	148	16.83	1	<b>\$496</b>
<b>A540.BLKC</b>							
<b>A540.WLNT</b>							
<b>A540.GREY</b>							

### STORAGE LAT

2 File

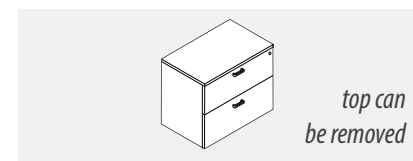

Product Code	D	W	H	Weight lbs.	Cubic ft.	Cartons	List Price
<b>A827.MAHO</b>	22½	35½	29	148	16.83	1	<b>\$960</b>
<b>A827.BLKC</b>							
<b>A827.WLNT</b>							
<b>A827.GREY</b>							

### STORAGE

Hutch Shell

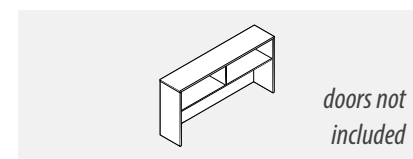

Product Code	D	W	H	Weight lbs.	Cubic ft.	Cartons	List Price
<b>A426.MAHO</b>	15	71	36	123	5.30	1	<b>\$464</b>
<b>A426.BLKC</b>							
<b>A426.WLNT</b>							
<b>A426.GREY</b>							

### DOOR SET

72W Laminate

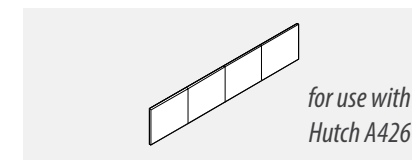

Product Code	D	W	H	Weight lbs.	Cubic ft.	Cartons	List Price
<b>A427.MAHO</b>	¾	69¼	15	22	1.24	1	<b>\$160</b>
<b>A427.BLKC</b>							
<b>A427.WLNT</b>							
<b>A427.GREY</b>							

### DOOR SET

72W Aluminum W/Frame

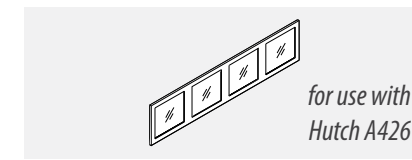

Product Code	D	W	H	Weight lbs.	Cubic ft.	Cartons	List Price
<b>A439</b>	¾	69¼	15	21	1.24	1	<b>\$416</b>

### STORAGE

Hutch Open

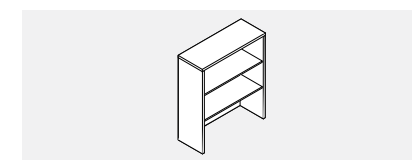

Product Code	D	W	H	Weight lbs.	Cubic ft.	Cartons	List Price
<b>A328.MAHO</b>	15	35½	36	95	3.39	1	<b>\$336</b>
<b>A328.BLKC</b>							
<b>A328.WLNT</b>							
<b>A328.GREY</b>							

### STORAGE

Bookcase 4 Shelf

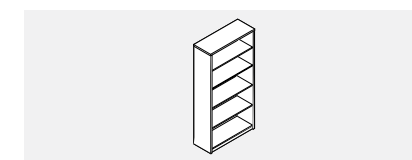



Product Code	D	W	H	Weight lbs.	Cubic ft.	Cartons	List Price
<b>A829.MAHO</b>	15	35½	65	172	5.79	1	<b>\$576</b>
<b>A829.BLKC</b>							
<b>A829.WLNT</b>							
<b>A829.GREY</b>							

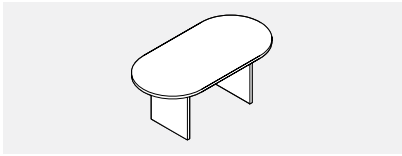

### TABLE

Conference Round	Product Code	D	W	H	Weight lbs.	Cubic ft.	Cartons	List Price
	A722.MAHO	36	36	29	111	6.95	1	<b>\$426</b>
	A722.BLKC							
	A722.WLNT							
	A722.GREY							

### TABLE

Conference Racetrack	Product Code	D	W	H	Weight lbs.	Cubic ft.	Cartons	List Price
	A720.MAHO	35	71	29	135	5.57	1	<b>\$620</b>
	A720.BLKC							
	A720.WLNT							
	A720.GREY							
	A723.MAHO	42	95	29	190	5.53	1	<b>\$800</b>
	A723.BLKC							
	A723.WLNT							
	A723.GREY							

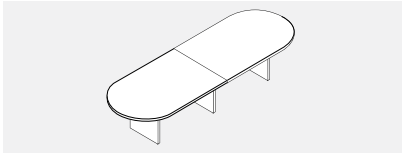
### TABLE

Conference Expandable	Product Code	D	W	H	Weight lbs.	Cubic ft.	Cartons	List Price
	AM408.MAHO	48	120	29	257	10.21	2	<b>\$1,480</b>
	AM408.BLKC							
	AM408.WLNT							
	AM408.GREY							
	AM409.MAHO	48	144	29	294	11.58	2	<b>\$1,840</b>
	AM409.BLKC							
	AM409.WLNT							
	AM409.GREY							

### TABLE

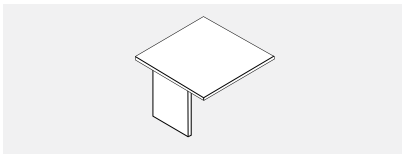
Segment Add-On	Product Code	D	W	H	Weight lbs.	Cubic ft.	Cartons	List Price
	A739.MAHO	48	48	29	103	4.92	1	<b>\$600</b>
	A739.BLKC							
	A739.WLNT							
	A739.GREY							

### ACCESSORY

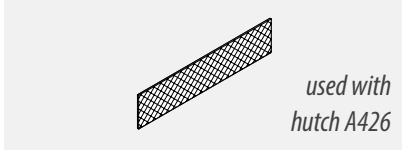
Tackboard	Product Code	D	W	H	Weight lbs.	Cubic ft.	Cartons	List Price
 used with hutch A426	A201.LIGHT	1½	68	18	10	1.05	1	<b>\$200</b>

### ACCESSORY

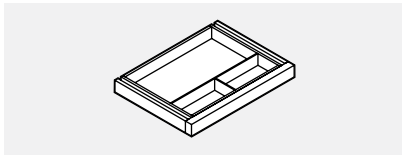
Center Drawer	Product Code	D	W	H	Weight lbs.	Cubic ft.	Cartons	List Price
	A830.MAHO	14	20	2	9	0.59	1	<b>\$72</b>
	A830.BLKC							
	A830.WLNT							
	A830.GREY							

# AMBER COLLECTION

## Specifications

### THERMALLY FUSED LAMINATE (TFL)

CHERRY MAN products are manufactured with premium grade materials. The Amber Collection is offered in four wood-grain finishes:

- MAHO** Sienna Mahogany
- BLKC** Black Cherry
- WLNT** Park Walnut
- GREY** Valley Grey

### SAMPLES

CHERRY MAN color samples are available from our customer service team, email [csr@cherrymanindustries](mailto:csr@cherrymanindustries)

### CONSTRUCTION. TOPS AND SUPPORT PANELS

Tops are 1" thick and feature a reeded edge on all four sides. Both tops and panels use a 3 ply balanced construction. All support panels include adjustable levelers.

### CONSTRUCTION. CASES

All cases are constructed utilizing 3 ply balanced panels. Adjustable levelers are provided in all cases.

### CONSTRUCTION. DRAWERS

Drawers are constructed utilizing 3 ply balanced panels.

### LOCKS

All pedestals and laterals with drawers include a front mounted lock. All units are keyed alike. Requests for different keying can be accommodated for an up-charge.

- Black Cherry, Park Walnut, and Sienna Mahogany have black locks.
- Valley Grey has satin grey locks.

### PULLS

Pulls are standard for all pedestals and laterals.

- Black Cherry, Park Walnut, and Valley Grey are available with satin grey aluminum pulls.
- Sienna Mahogany comes with black aluminum pulls.



AM-421N.GREY  
U-DESK RECTANGULAR STORAGE PED  
VALLEY GREY



AM-421N.WLNT  
U-DESK RECTANGULAR STORAGE PED  
PARKER WALNUT



AM-421N.MAHO  
U-DESK RECTANGULAR STORAGE PED  
SIENNA MAHOGANY



AM-421N.BLKC  
U-DESK RECTANGULAR STORAGE PED  
BLACK CHERRY

# AMBER COLLECTION

## Specifications

### GROMMETS

Grommets for cables are provided in all work surfaces and hutches.

- Black Cherry, Park Walnut, and Sienna Mahogany have black grommets.
- Valley Grey has satin grey grommets.

### PRODUCT ASSEMBLY.

Most CHERRY MAN product is shipped in a Ready to Assemble state.

- The following items are Ready to Assemble with the aid of cam lock connectors and pre-drilled holes:

- desks
- returns / bridges
- bridge credenzas / knee-space credenzas
- conference tables
- bookcases
- hutch storage
- cabinet storage
- door storage

- The following items are Pre Assembled requiring placement only:

- pedestal storage
- lateral storage

### PRODUCT ORDERING

The Amber Collection is divided into a Typicals, followed by a Components section in this Specification Guide. For ease of ordering with one product number, the Typicals section lists complete units and configurations and includes:

- desks with pedestals
- full credenzas / knee-space credenzas
- L desks
- U desks with hutch storage
- reception desks
- conference tables

The Components section enables the ordering of individual items where alternate storage choices and/or alternate sizes of units are required. This section includes:

- desk shells
- return shells
- bridges
- credenza shells
- pedestal storage
- lateral storage
- hutch storage
- bookcases
- conference tables
- accessories



AM-405N.GREY  
U-DESK CONFIGURATION  
VALLEY GREY



AM-405N.WLNT  
U-DESK CONFIGURATION  
PARKER WALNUT



AM-405N.MAHO  
U-DESK CONFIGURATION  
SIENNA MAHOGANY



AM-405N.BLKC  
U-DESK CONFIGURATION  
BLACK CHERRY



SEATING

# COLLECTIONS

Our Cherry Man task chairs are fully equipped to meet today's functional requirements. The collections are uniquely scaled to fit any environment without compromising comfort.



- / 01 – JEPPE / GRAY  
SEAT IS GRAY FABRIC: F03-808  
SEAT & BACK / 50,000 DBL. RUBS  
SEAT & BACK / 100% POLYESTER
- / 02 – JEPPE / BLACK  
SEAT IS BLACK FABRIC: F03-807  
SEAT & BACK / 50,000 DBL. RUBS  
SEAT & BACK / 100% POLYESTER
- / 03 – EON SERIES / MESH GRAY  
SEAT IS BARBADINE FABRIC COAL  
MESH BACK 102G GRAY  
SEAT & MESH / 100,000 DBL. RUBS  
SEAT & MESH / 100% POLYESTER
- / 04 – EON SERIES / MESH BLACK  
SEAT IS BARBADINE FABRIC BLACK  
MESH BACK 102B BLACK  
SEAT & MESH / 100,000 DBL. RUBS  
SEAT & MESH / 100% POLYESTER
- / 05 – OROBLANCO / MESH GRAY  
SEAT IS BARBADINE FABRIC COAL  
SEAT & MESH / 100,000 DBL. RUBS  
SEAT & MESH / 100% POLYESTER
- / 06 – OROBLANCO / MESH BLACK  
SEAT IS BARBADINE FABRIC BLACK  
SEAT & MESH / 100,000 DBL. RUBS  
SEAT & MESH / 100% POLYESTER

TO REQUEST A SWATCH EMAIL  
[csr@cherrymanindustries.com](mailto:csr@cherrymanindustries.com)  
 or CALL US AT 219.248.7703

# JEPPE

## Task Chair

New for 2024, Our Jeppe Chair is manufactured with great design at an affordable price. Do your work comfortably and maintain your posture with JEPPE. Upholstered with a breathable fabric and featuring two locking positions, this chair is perfect for all home or office settings.

**FRAME:** Black frame with matching black upholstered seat and back, also available in gray fabric seat and back.

**BASE:** 5-star nylon base with PU casters.

**MECHANISM:** Weight synchro mechanism with 2 locking position and 18-degree tilt. Pneumatic seat height adjustment.

**ARMS:** 3D adjustable arms with PU pads.

**SEAT:** 3" thick polyurethane contoured seat.

**FABRIC SEAT AND BACK:** 50,000 double rubs.



**WEIGHT CAPACITY:** 300 lbs.

**SHIPPING WEIGHT:** 37 lbs,

**WARRANTY:** 5-year

**PRODUCT DIMENSIONS:**  
 Overall: W25" x D24" x H39¼"-42¾"  
 Height: 39½" to 42½"  
 Seat Width: W19¼"  
 Seat Depth: 17"  
 Seat Height: 17¾"-21"  
 Arm Height: 23.8" to 27"  
 Depth/Length: 24"  
 Width: 25"



	Product Code	D	W	H	Weight lbs.	Cartons	List Price
	<b>10632-BLK</b>	Overall 24"	25"	39¼"-42¾"	31.31	1	<b>\$688</b>
	<b>10632-GRY</b>	Overall 24"	25"	39¼"-42¾"	31.31	1	<b>\$688</b>

# EON

## Mesh Back Task Chair

A budget-friendly mesh back task chair with top-tier ergonomic features, the Eon from Cherry Man is the perfect choice. This best-selling swivel chair offers a 3" contoured seat, polished aluminum 5-star base, advanced synchro-tilt mechanism with a 2" seat slider, and multi-functional arms for ideal maximum comfort.

**FRAME:** Available in black frame with matching black upholstered seat, black mesh back and black arm pads, or white frame with gray upholstered seat, gray mesh back and gray arm pads.

**BASE:** Polished aluminum 5-star base.

**MECHANISM:** Advanced Synchro-Tilt with 3 locking position & tension crank. Seat slider adjustment and pneumatic seat height adjustment.

**ARMS:** Height adjustable (3½"), arm pad sliders (1½") and arm pad pivot. Lock kit is included for slide and pivot.

**SEAT:** 3" thick polyurethane contoured seat in fabric.

**FABRIC SEAT AND BACK MESH:** 100,000 double rubs.

**WEIGHT CAPACITY:** 300 lbs.

**SHIPPING WEIGHT:** 50 lbs.



**SHIPPING VOLUME:** 5.22 cubic ft.

**WARRANTY:** Limited Lifetime.

**PRODUCT DIMENSIONS:**

Overall: W28" x D23¼"-25¼" x H38¼"-43"  
 Width at Arms: 28"  
 Between Arms: 20.5"  
 Height: 38¼" to 43"  
 Seat Width: 20"  
 Seat Height: 17¼"-22"  
 Seat Depth: 18½" to 20½"  
 Seat To Top of Back: 22¾"



	Product Code	D	W	H	Weight lbs.	Cartons	List Price
	<b>415B</b>	Overall 23¼-25¼"	28"	38¼-43"	44	1	<b>\$920</b>
	<b>415W</b>	Overall 23¼-25¼"	28"	38¼-43"	44	1	<b>\$920</b>

# EON

## Guest Chair / Set of Two

The Cherry Man Eon Collection introduces guest chairs tailored for professional settings, boasting a remarkable fusion of functionality, appeal, and value. These high-quality chairs are designed to elevate any environment with their sophisticated blend of style and practicality.

**FRAME:** Available with matching black upholstered seat, black mesh back and black arm caps, or with grey upholstered seat, grey mesh back and white arm caps.

**ARMS:** Fixed arms

**SEAT:** 2" thick polyurethane contoured seat in fabric.

**FABRIC SEAT AND BACK MESH:** 100,000 double rubs.

**WEIGHT CAPACITY:** 300 lbs.

**SHIPPING WEIGHT:** 48 lbs. [Set of Two]



**SHIPPING VOLUME:** 6.6 cubic ft. [Set of Two]

**WARRANTY:** Limited Lifetime.

**PRODUCT DIMENSIONS:**

Overall: W22" x D23¼" x H34¼"  
 Width at Arms: 22"  
 Between Arms: 18"  
 Height: 34¼"  
 Seat Width: 18"  
 Seat Height: 17"  
 Seat Depth: 18"  
 Arm Rest Height: 26"



	Product Code	D	W	H	Weight lbs.	Cartons	List Price
	<b>414B</b>	Overall 23¼"	22"	34¼"	21	1	<b>\$928 S/2</b>
	<b>414W</b>	Overall 23¼"	22"	34¼"	21	1	<b>\$928 S/2</b>

*dims shown for individual chair*

# OROBLANCO

## Mesh Back Task Chair

The Oroblanco task chair by Cherry Man boasts an eye-catching mesh back design complemented by adjustable arms and a sturdy 5-star base. Backed by a limited lifetime warranty, Oroblanco office chairs guarantee unparalleled quality and enduring performance, making them an exceptional choice. Oroblanco stands out as a premium task chair that combines cutting-edge design with affordability.

**FRAME:** Available in black frame with matching black upholstered seat, black mesh back and black arm pads, or white frame with gray upholstered seat, gray mesh back and gray arm pads.

**BASE:** Polished Aluminum 5-star base.

**MECHANISM:** Advanced Synchro-Tilt with seat slider adjustment [2"] and pneumatic seat height adjustment [4"]. 4 position tilt, one lock position, three float positions & tension crank.

**ARMS:** Height adjustable [3½"], arm pad sliders [1½"] and arm pad pivot. Lock kit is included for slide and pivot.

**SEAT:** 2" thick polyurethane contoured seat in fabric.

**FABRIC SEAT AND BACK MESH:** 100,000 double rubs.

**WEIGHT CAPACITY:** 300 lbs.

**SHIPPING WEIGHT:** 45 lbs.



**SHIPPING VOLUME:** 5.22 cubic ft.

**WARRANTY:** Limited Lifetime.

**PRODUCT DIMENSIONS:**

Overall: W27¾" x D21¼" x H39"-43"  
 Width at Arms: 27¾"  
 Between Arms: 21"  
 Seat Width: 19½"  
 Seat Height: 17¼"-21¼"  
 Seat Depth: 17-19"



	Product Code		D	W	H	Weight lbs.	Cartons	List Price
	<b>402B</b>	Overall	17-19"	19 ½"	17¼"-21¼"	37	1	<b>\$1,064</b>
	<b>402W</b>	Overall	17-19"	19 ½"	17¼"-21¼"	37	1	<b>\$1,064</b>

# OROBLANCO

## Guest Chair / Set of Two

The Oroblanco Collection features guest chairs designed specifically for professional interiors, combining superior quality with an exceptional balance of functionality, appeal, and value. These chairs are meticulously crafted to elevate any workspace, ensuring both comfort and style for discerning users.

**FRAME:** Available with matching black upholstered seat, black mesh back and black arm caps, or with grey upholstered seat, grey mesh back and white arm caps.

**ARMS:** Fixed arms.

**SEAT:** 2" thick polyurethane contoured seat in fabric.

**FABRIC SEAT AND BACK MESH:** 100,000 double rubs.

**WEIGHT CAPACITY:** 300 lbs.

**SHIPPING WEIGHT:** 47 lbs. [Set of Two]



**SHIPPING VOLUME:** 6.6 cubic ft. [Set of Two]

**WARRANTY:** Limited Lifetime.

**PRODUCT DIMENSIONS:**

Overall: W21¼" x D23¼" x H34¼"  
 Width at Arms: 17"  
 Between Arms: 18 ½"  
 Seat Height: 17¼"  
 Seat Depth: 17¾"  
 Arm Rest Height: 22"



	Product Code		D	W	H	Weight lbs.	Cartons	List Price
	<b>403B</b>	Overall	23¼"	21¼"	34¼"	21	1	<b>\$1,056</b> S/2
	<b>403W</b>	Overall	23¼"	21¼"	34¼"	21	1	<b>\$1,056</b> S/2

*dims shown for individual chair*



Limited Lifetime

# WARRANTY

Our Contract-Grade collections seamlessly marry modern sophistication with the robust strength and durability required for the demands of Contract and Hospitality environments.

Each Contract-Grade item is backed by a *Limited Lifetime Warranty*, ensuring long-lasting quality and peace of mind.



End to End

# DESIGN LIVE

We've partnered with 2020 Cap Complete because they empower designers to customize products and envision spaces with ease. Their comprehensive software solutions allow professional designers to use our Cherry Man products in their projects.

The 2020 Visual Impression feature in the Cap Office Design Software will allow you to present your designs in 3D making for a smoother project flow.

[WWW.2020SPACES.COM](http://WWW.2020SPACES.COM)



# CHERRY MAN

## Terms & Conditions

### IN-STOCK PROGRAM AVAILABILITY & LEAD TIME

Products in the In-Stock Program typically ship within 5 business days. Occasionally, high demand may deplete stock, transit time usually ranges from 5 to 7 business days.

### ORDER ACKNOWLEDGMENT

Cherry Man sends acknowledgments on all orders. The Order Acknowledgment serves as the final agreement between the Company and the customer, superseding all previous communications regarding that order.

### BACK ORDERS

In the event an item is not available, you can choose from the following options:

- *OPTION 1:* Hold order until back order is available.
- *OPTION 2:* Partial ship available products and ship back order items when product becomes available. Minimum freight charges apply for both the initial partial shipment and subsequent back order shipments.

### ZONE PRICING

Standard program pricing is based on the ship to location, designated as below.

#### ZONE ONE: Southern California & Georgia

- Minimum \$750 Net or \$75 shipping charge.

#### ZONE TWO: California, Nevada, Arizona, Florida, South Carolina, North Carolina, Tennessee, Alabama, Mississippi and Louisiana

- Minimum \$1,250 Net or \$125 shipping charge.

#### ZONE THREE: The Balance of the continental United States not listed in zones one and two.

- Minimum \$1,750 Net or \$175 shipping charge.

### ACCESSORIAL CHARGES

Will be applied to the below shipments, rates are subject to change without notice.

- Liftgate - \$75 net
- Inside delivery - \$75 net
- Residential, Non-commercial, Limited access - \$175 net
- Call before - \$10 net

### CANCELLATION AND ORDER CHANGES

Cancellations or revisions will not be accepted once the order is confirmed.

### RETURNS

Returns will not be accepted once the order has been shipped.

### FREIGHT DAMAGE & REFUSALS | SHORTAGES

Customer must note any freight damages or shortages on the Delivery Receipt. Claims must be filed through our website <http://www.cherrymanindustries.com/claims/> or by emailing [csr@cherrymanindustries.com](mailto:csr@cherrymanindustries.com)

#### 1. FREIGHT DAMAGE

File with photos of damaged cartons within 15 days of receipt of goods.

#### 2. CONCEALED DAMAGE & MANUFACTURING DEFECT

File within 30 calendar days of receipt of goods. Customer must attach photos of each product item and corresponding carton.

#### 3. CONTAINER PURCHASE

File within 30 days of receipt of goods. The claim may not be approved if the product is moved from the original 'ship to' location.

### LIMITED LIFETIME WARRANTY

We warrant to the original purchaser that products are free from defects in design, material and workmanship under normal commercial use and care. The warranty covers single shift (standard 8 hours per day, 5 days a week) for individuals under 300 lbs. All products are covered by the Limited Lifetime Warranty with the exception of the items below:

#### 10 YEAR WARRANTY

- Amber Collection

#### 5 YEAR WARRANTY

- Seating

### WARRANTY EXCLUSIONS

- Abuse, misuse, modifications, extreme conditions, improper installation or storage, floor samples, rental use, unauthorized dealer sales, cleaning chemical damage, and dry transfer from clothing are not covered.

### WARRANTY REQUESTS

All warranty requests must be made through dealers where the product was purchased.

### DISCLAIMER

Prices shown are list prices. We reserve the right to correct any typographical errors and make product changes without prior notice. Measurements listed in price book are rounded off.

### GROMMETS

Grommets for cables are provided in all work surfaces and hutches.

Black Cherry, Park Walnut, and Sienna Mahogany have black grommets.

Valley Grey has satin grey grommets.

### PRODUCT ASSEMBLY AMBER COLLECTIONS

Most product are shipped in a Ready to Assemble state.

### ORDERING

- Reach out to your Sales Representative to open an account. Terms are available upon credit application approval.
- Orders must include all necessary details, including requested ship dates. Standard shipping times are within 5 business days.
- Orders requiring shipment more than 14 days after order confirmation must be fully prepaid and shipped within 30 days of payment confirmation.
- A storage fee will be applied after 30 days of order confirmation, but not shipped.

### STORAGE FEE

- Orders will be held free of charge for a maximum of 30 days from the date that the orders are complete and available to ship. If a hold order is requested by the customer, payment will be required in full and the order may not be cancelled, modified, or refunded. In addition, a storage fee will be applied after 30 days of order confirmation.

### SUSTAINABILITY

We recognize the impact products have on the environment and are committed to sustainability as a guiding principle in our business. Cherry Man uses renewable and recycled materials in our products and processes wherever possible.

### CARB COMPLIANCE

Cherry Man's products meet the California Air Resources Board Composite Wood Air Toxic Control Measure Standard. The C.A.R.B. rule mandates the strictest formaldehyde emission levels in the world on all composite wood products sold in California.

### RECYCLED MATERIAL

Amber TFL is constructed of particleboard cores manufactured from recycled post-industrial material and uses recyclable aluminum and glass.

### RECYCLED MATERIAL

Amber products are constructed of particleboard cores manufactured from recycled post-industrial material and use recyclable aluminum and glass.

**We recognize the impact** our products have on the environment and are committed to sustainability as a guiding principle in our business.

## OUR TEAM

At Cherry Man, our team is dedicated to supporting all our clients with their design and buying needs for office furniture, ensuring a seamless experience from selecting a desk to finding the perfect task chair.

We pride ourselves on offering expert guidance and personalized solutions to create functional and stylish office environments.



SANDRA MONTELONGO  
CUSTOMER SERVICE REPRESENTATIVE  
EAST COAST  
smontelongo  
@cherrymanindustries.com



SELENA YBANEZ  
CUSTOMER SERVICE REPRESENTATIVE  
WEST COAST  
sybanez  
@cherrymanindustries.com



ELIZABETH RAMIREZ  
ACCOUNTS RECEIVABLE  
eramirez  
@cherrymanindustries.com



TINA SIBBLE  
ACCOUNTING MANAGER  
tsibble  
@cherrymanindustries.com

### SOUTHEAST FULFILLMENT CENTER

2000 BUFORD MILL DRIVE, BUILDING 200  
BUFORD, GA 30519

BUSINESS HOURS:  
8:30AM-4:00PM [EASTERN STANDARD TIME]

MAIN LINE: 219.248.7703

CONTACT: [csr@cherrymanindustries.com](mailto:csr@cherrymanindustries.com)

[WWW.CHERRYMANINDUSTRIES.COM](http://WWW.CHERRYMANINDUSTRIES.COM)



EON TASK



OROBLANCO TASK



JEPPE TASK